

INSTRUCTIONBOOK

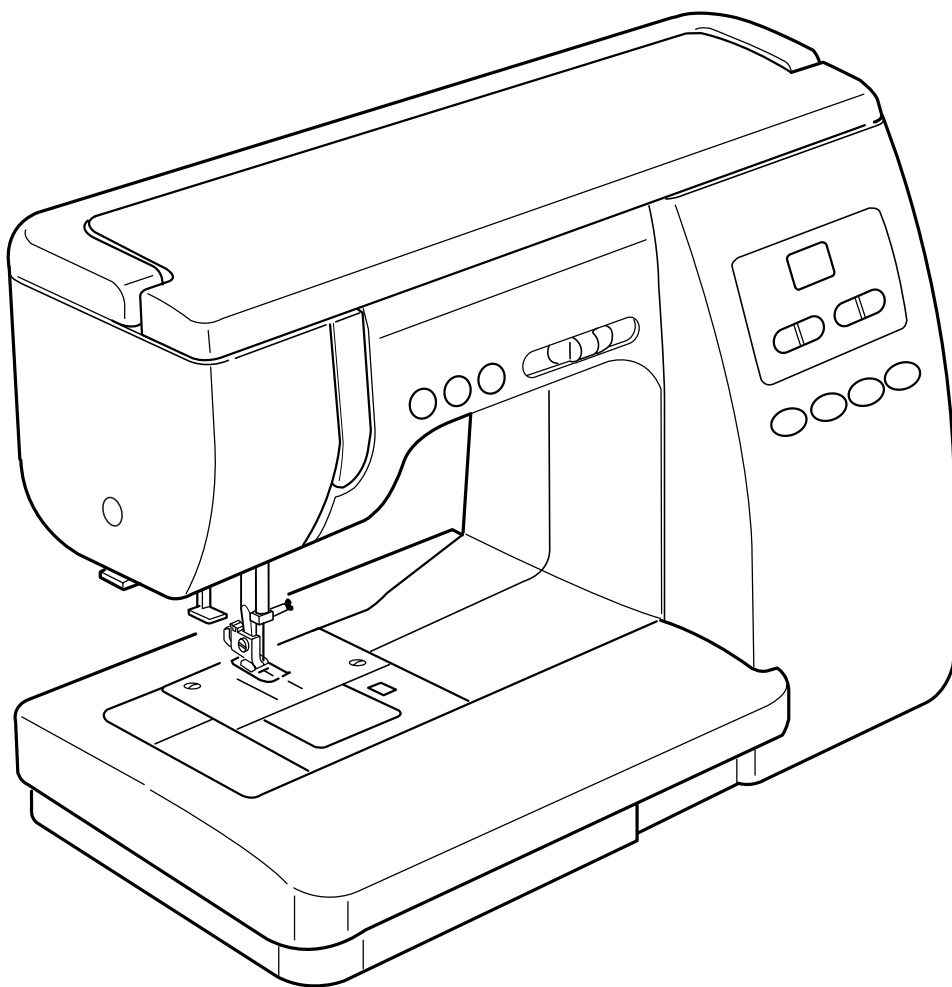

6260

Quilter's Companion

IMPORTANT SAFETY INSTRUCTIONS

When using an electrical appliance, basic safety precautions should always be followed, including the followings:

Read all instructions before using this appliance.

DANGER— To reduce the risk of electric shock:

1. An appliance should never be left unattended when plugged in. Always unplug this sewing machine from the electric outlet immediately after using and before cleaning.
2. Always unplug before replacing a sewing machine bulb. Replace bulb with same type rated 12 Volts, 5 Watts.

WARNING— To reduce the risk of burns, fire, electric shock, or injury to persons:

1. Do not allow to be used as a toy. Close attention is necessary when this sewing machine is used by or near children.
2. Use this appliance only for its intended use as described in this owner's manual.
Use only attachments recommended by the manufacturer as contained in this owner's manual.
3. Never operate this sewing machine if it has a damaged cord or plug, if it is not working properly, if it has been dropped or damaged, or dropped into water.
Return this sewing machine to the nearest authorized dealers or service center for examination, repair, electrical or mechanical adjustment.
4. Never operate the appliance with any air opening blocked. Keep ventilation openings of this sewing machine and foot controller free from accumulation of lint, dust and loose cloth.
5. Never drop or insert any object into any opening.
6. Do not use outdoors.
7. Do not operate where aerosol (spray) products are being used or where oxygen is being administered.
8. To disconnect, turn all controls to the off ("0") position, then remove plug from outlet.
9. Do not unplug by pulling on cord. To unplug, grasp the plug, not the cord.
10. Keep fingers away from all moving parts. Special care is required around the sewing machine needle.
11. Always use the proper needle plate. The wrong plate can cause the needle to break.
12. Do not use bent needles.
13. Do not pull or push fabric while stitching. It may deflect the needle causing it to break.
14. Switch this sewing machine off ("0") when making any adjustment in the needle area, such as threading the needle, changing the needle, threading the bobbin or changing the presser foot, and the like.
15. Always unplug this sewing machine from the electrical outlet when removing covers, lubricating, or when making any other adjustments mentioned in this owner's manual.

SAVE THESE INSTRUCTIONS

TABLE OF CONTENTS

Name of Parts	2	Overcasting	22
Standard Accessories and Storage	3	• Zigzag stitch	22
Extension Table and Free Arm Sewing	4	• Multiple zigzag stitch (Tricot stitch)	22
GETTING READY TO SEW		• Knit stitch	22
Connecting to the Power Supply	5	• Overedge stitch	23
Controlling Sewing Speed	5	• Serging stitch	23
Function Keys and Buttons	6	Sewing on Buttons	24
• Reverse stitch button	6	Automatic Buttonhole	25-31
• Auto-lock button	6	Corded buttonhole	32
• Needle Up/Down button	6	Zipper Application	33-35
Dropping the Feed Dog	7	Rolled Hem	36
Adjusting the Foot Pressure	7	Eyelet	36
Changing the Presser Foot	8	Blind Hem Stitch	37
Detaching and Attaching the Foot Holder	8	Darning	38
Raising and Lowering the Presser Foot	9	SEWING APPLICATION AND DECORATIVE STITCHES	
Balancing Thread Tension	9	Appliqué	39
• Auto tension	9	Quilting	39
• Manual tension adjustment	9	Pin Tucking	40
Changing the Needle	10	Patchwork	40
Selecting Threads and Needles	10	Fagoting	41
Winding the Bobbin	11	Scallop Stitch	41
• Removing the Bobbin	11	Smocking	42
• Winding the Bobbin	11	Decorative Satin Stitches	42
• Inserting the Bobbin	12	Pattern Combination	43
Threading the Machine	13	Cross Stitch	43
• Threading the needle thread	13	Cording	44
Automatic Needle Threader	14	Elastic Stretch Stitch	44
Drawing Up Bobbin Thread	15	Decorative Stretch Stitch	45
Selecting the Stitch Pattern	16	Adjusting Stretch Stitch Balance	45
Adjusting Stitch Width	16	CARE OF YOUR MACHINE	
Adjusting Stitch Length	16	Replacing the Light Bulb	46
UTILITY STITCHES		Cleaning Hook Race and Feed Dog	47
Straight Stitch	17	PROBLEMS AND WARNING SIGNALS	48
• Starting to sew	17	TROUBLESHOOTING	49
• Changing sewing direction	17		
• Fastening the seam/Thread cutter	17		
• Adjusting the stitch length	18		
• Changing the needle drop position	18		
• Using the seam guide lines	19		
• Sewing from the edge of thick fabric	19		
Variety of straight stitches	20		
Basic Zigzag Stitch	21		
• Adjusting the stitch width	21		
• Adjusting the stitch length	21		

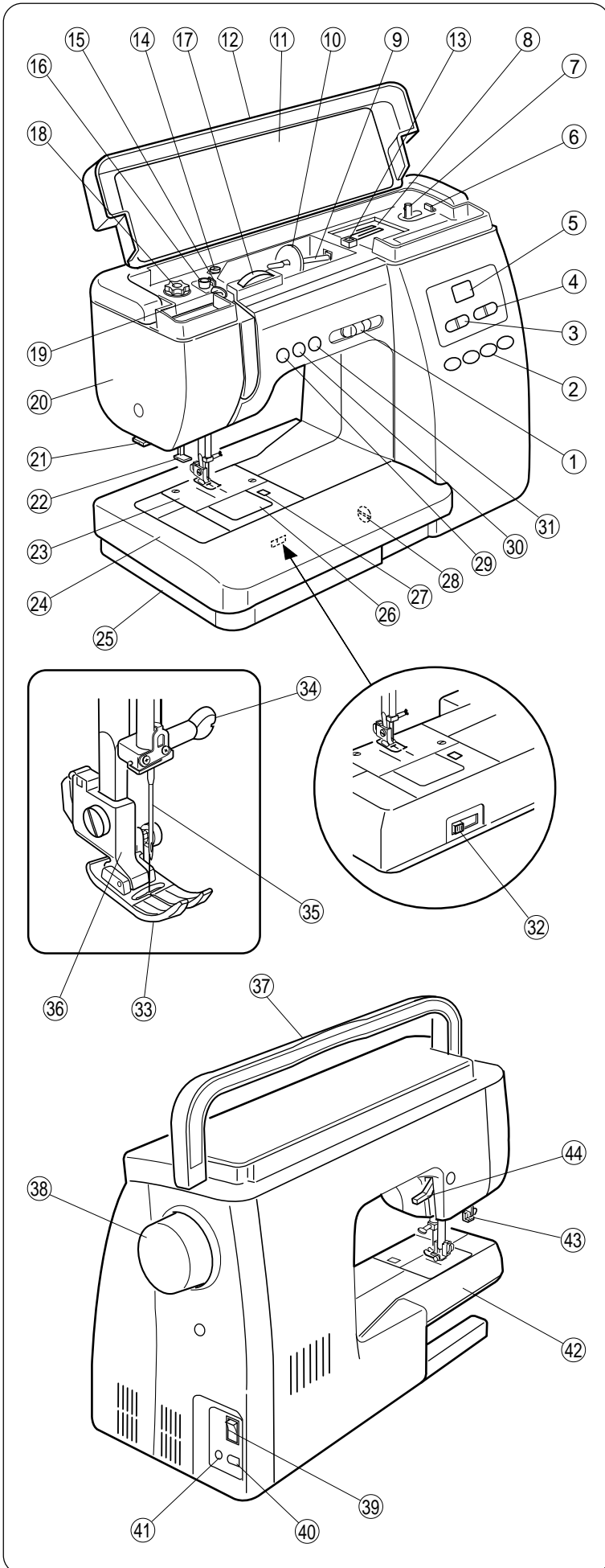

Name of Parts

- ① Speed control lever
- ② Direct pattern selection keys
- ③ Stitch width control keys
- ④ Stitch length control keys
- ⑤ LED display
- ⑥ Bobbin winder stopper
- ⑦ Bobbin winder spindle
- ⑧ Accessory storage compartment
- ⑨ Spool pin
- ⑩ Spool holder
- ⑪ Stitch reference chart
- ⑫ Top cover
- ⑬ Hole for additional spool pin
- ⑭ Bobbin winder thread guide
- ⑮ Thread guide A
- ⑯ Thread guide B
- ⑰ Tension control dial
- ⑱ Foot pressure control dial
- ⑲ Thread take-up lever
- ⑳ Faceplate
- ㉑ Thread cutter
- ㉒ Automatic needle threader
- ㉓ Needle plate
- ㉔ Extension table
- ㉕ Accessory storage box
- ㉖ Hook cover plate
- ㉗ Hook cover plate release button
- ㉘ Stitch balance adjusting dial
- ㉙ Reverse stitch button
- ㉚ Auto lock button
- ㉛ Needle Up/Down button
- ㉜ Drop feed lever
- ㉝ Zigzag foot
- ㉞ Needle clamp screw
- ㉟ Needle
- ㊱ Presser foot holder
- ㊲ Carrying handle
- ㊳ Handwheel
- ㊴ Power switch
- ㊵ Machine socket for power cord
- ㊶ Machine socket for foot control
- ㊷ Free arm
- ㊸ Buttonhole lever
- ㊹ Presser foot lifter

NOTE: The design and specifications are subject to change without prior notice.

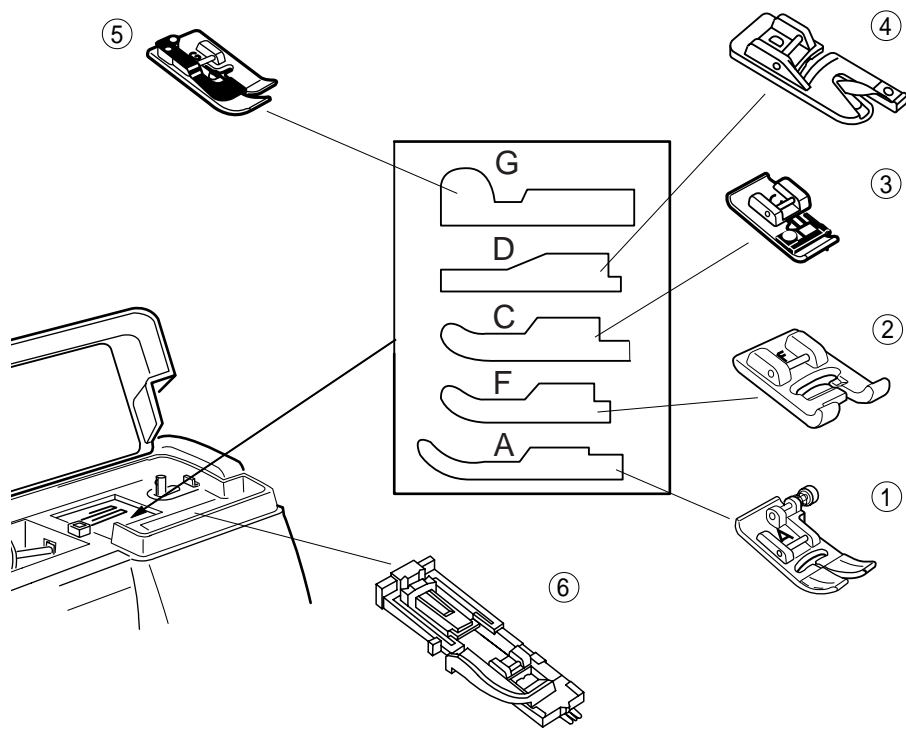

Standard Accessories and Storage

- ① A: Zigzag foot (set in the machine)
- ② F: Satin stitch foot
- ③ C: Overedge foot
- ④ D: Rolled hem foot
- ⑤ G: Blind hem foot
- ⑥ R: Automatic buttonhole foot

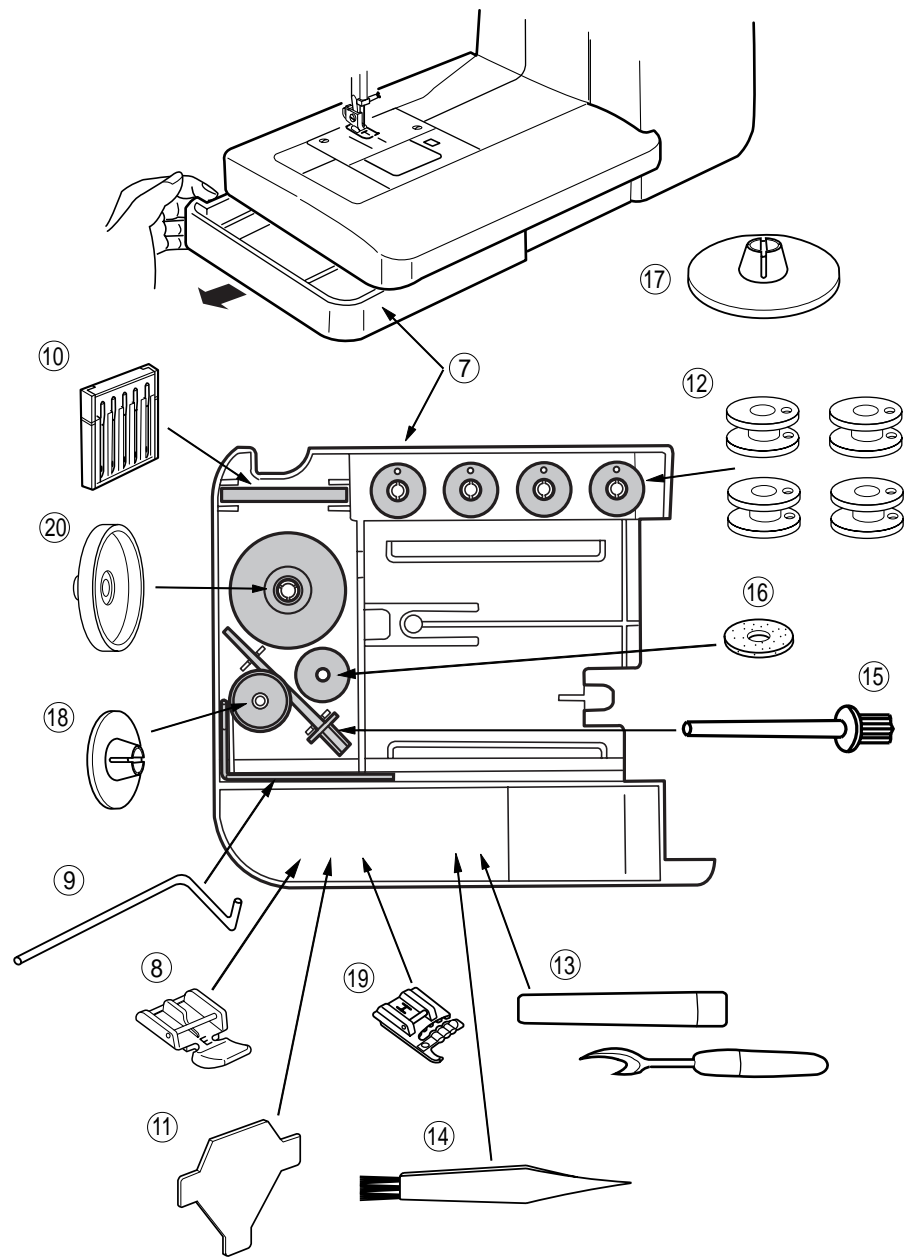

Accessory storage box

Accessories are conveniently stored in the storage box. Draw out the storage box by pulling the dent on the box to the left.

- ⑦ Accessory storage box
- ⑧ E: Zipper foot
- ⑨ L: Quilting bar
- ⑩ Set of needles
- ⑪ Screwdriver
- ⑫ Bobbins
- ⑬ Seam ripper (Buttonhole opener)
- ⑭ Lint brush
- ⑮ Additional spool pin
- ⑯ Felt
- ⑰ Spool holder (Large) (set on the spool pin)
- ⑱ Spool holder (Small)
- ⑲ H: Cording foot
- ⑳ Spool stand

NOTE: The design and specifications are subject to change without prior notice.

Extension Table and Free Arm Sewing

1

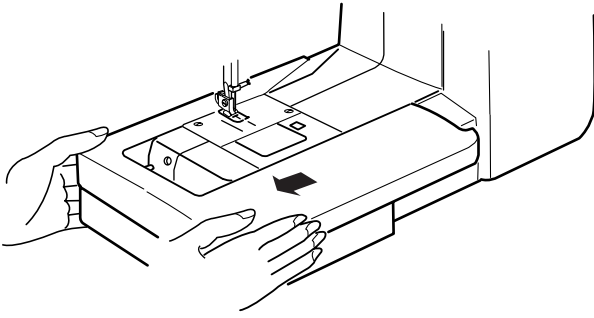

1 To detach:

Pull the extension table to the left.

2

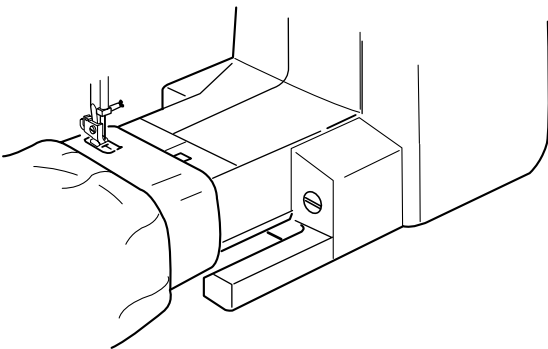

2 Free arm sewing:

The free arm is useful for stitching sleeves, waistbands, pant legs or any tubular garment, also for darning socks or mending knees, elbows and children's wear.

3

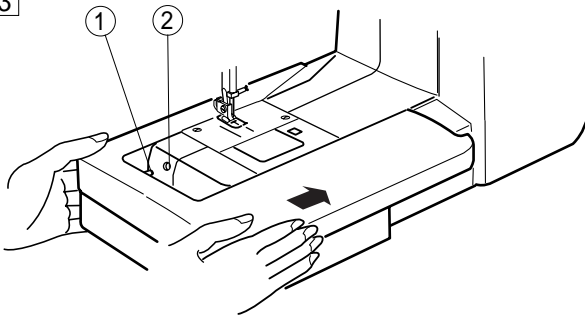

3 To attach:

Slide the extension table along the free arm, inserting the pin into the hole to attach.

- ① Pin
- ② Hole

GETTING READY TO SEW

Connecting to the Power Supply

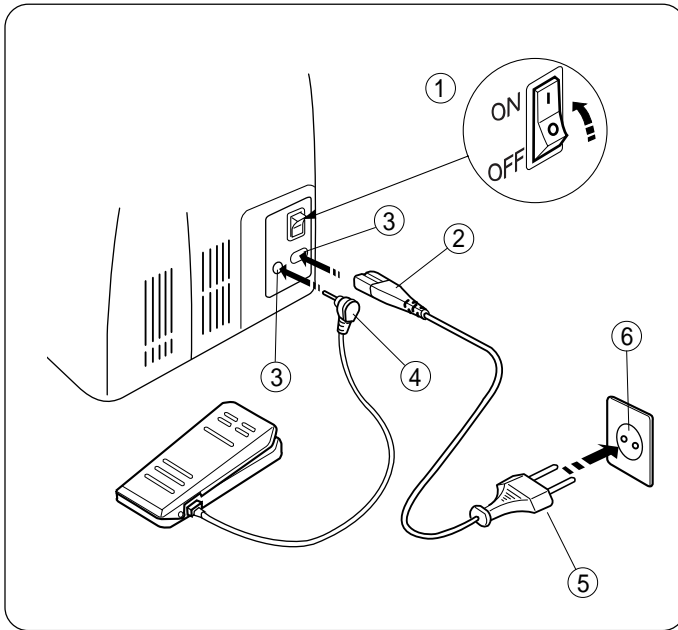

1. Turn the power switch OFF.
2. Insert the foot control jack into the machine socket.
3. Insert the machine plug into the machine socket.
4. Insert the power supply plug into the outlet.
5. Turn the power switch ON.

- ① Power switch
- ② Machine plug
- ③ Machine socket
- ④ Controller plug
- ⑤ Power supply plug
- ⑥ Outlet

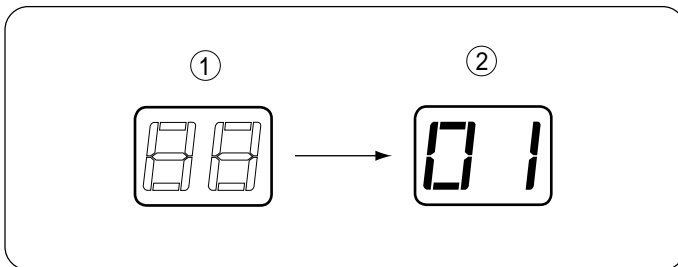

The LED display will show "01" (straight stitch) after one second.

- ① LED display
- ② Initial setting

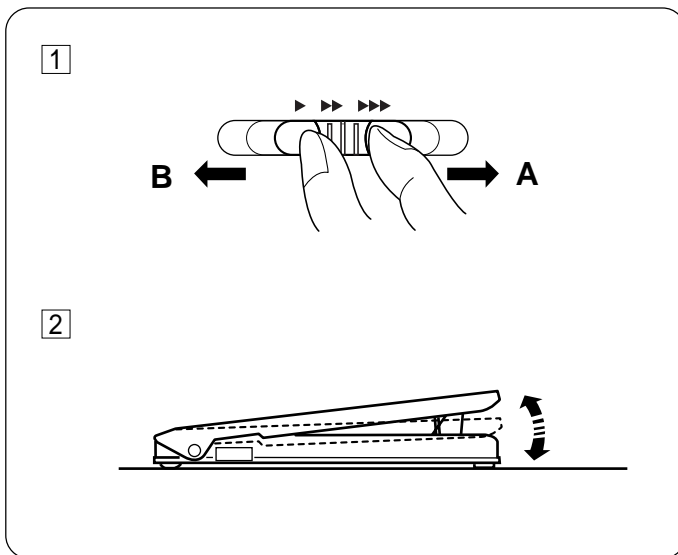

Controlling Sewing Speed

1 Speed control lever:

You can set the maximum speed by the speed control lever.

A: Slide the lever to the right for higher speed.

B: Slide the lever to the left for slower speed.

2 Foot control:

Sewing speed is varied by the foot control.

The harder you depress the foot control, the faster the machine runs.

CAUTION: Do not place any thing on the foot control when the machine is not in use.

OPERATING INSTRUCTIONS:

The symbol "○" of a switch indicates the "OFF" position of a switch.

For appliances with a polarized plug (one blade is wider than the other).

To reduce the risk of electric shock, this plug is intended to fit in a polarized outlet only one way. If it does not fit fully in the outlet, reverse the plug.

If it still does not fit, contact a qualified electrician to install the proper outlet. Do not modify the plug in any way.

Foot controller Model 21249 is used with sewing machine Model 6260.

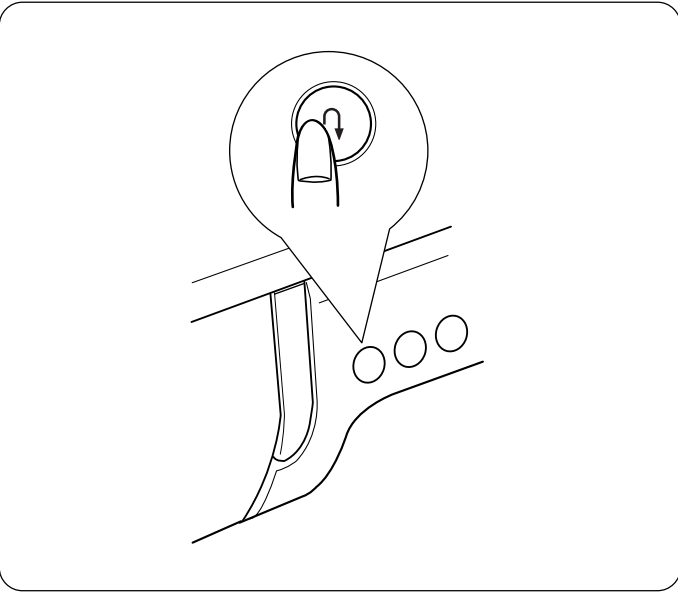

Function Keys and Buttons

• Reverse stitch button

While the reverse stitch button is pressed, the machine sews backwards when the pattern 01, 02, 05 or 10 has been selected.

The machine will immediately lock the stitches and stop automatically when other stitch has been selected.

- * In case of 02, the machine will sew in reverse and stop automatically.

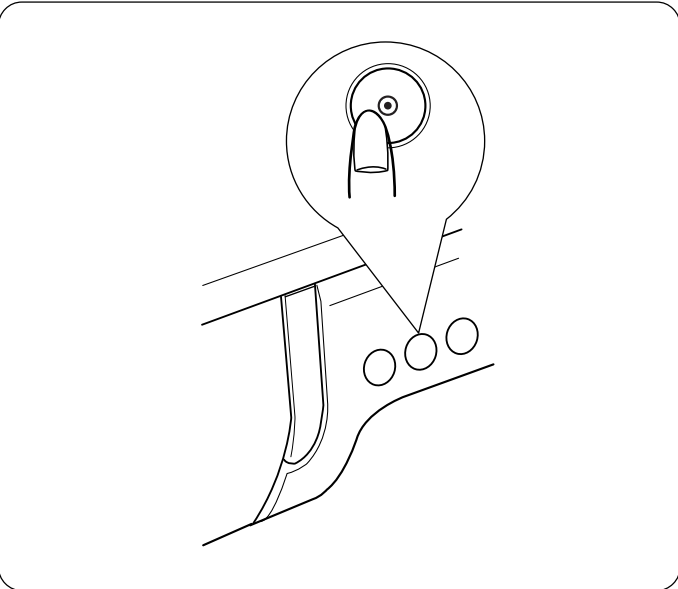

• Auto-lock button

The machine will lock the stitches and stop automatically when the Auto-lock button is pressed while sewing the pattern 01, 02, 05 or 10.

The machine will sew to the end of the pattern being sewn and lock the stitches to stop automatically when other pattern has been selected.

NOTE: You can sew a single unit of the selected pattern if you press the Auto-lock button before starting to sew.

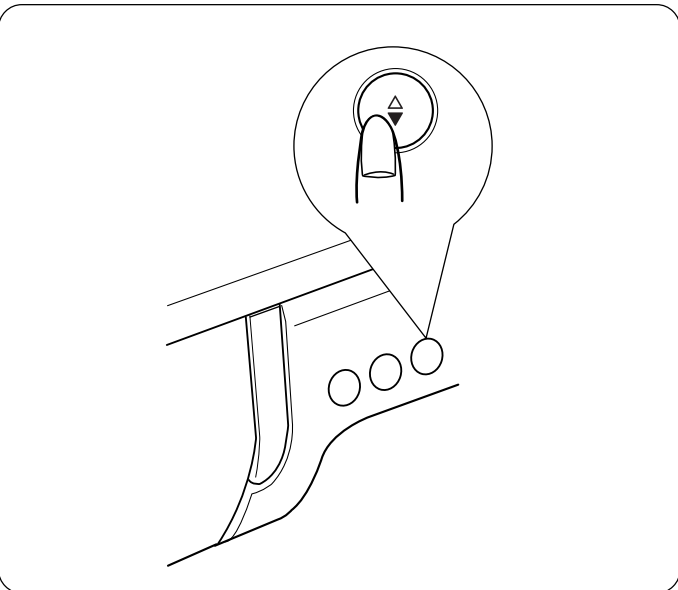

• Needle Up/Down button

Press this button to bring the needle up or down.

The machine will stop with the needle up or down, depending on its position before starting.

When you turn off the machine and turn it on again, the machine will stop with the needle in up position.

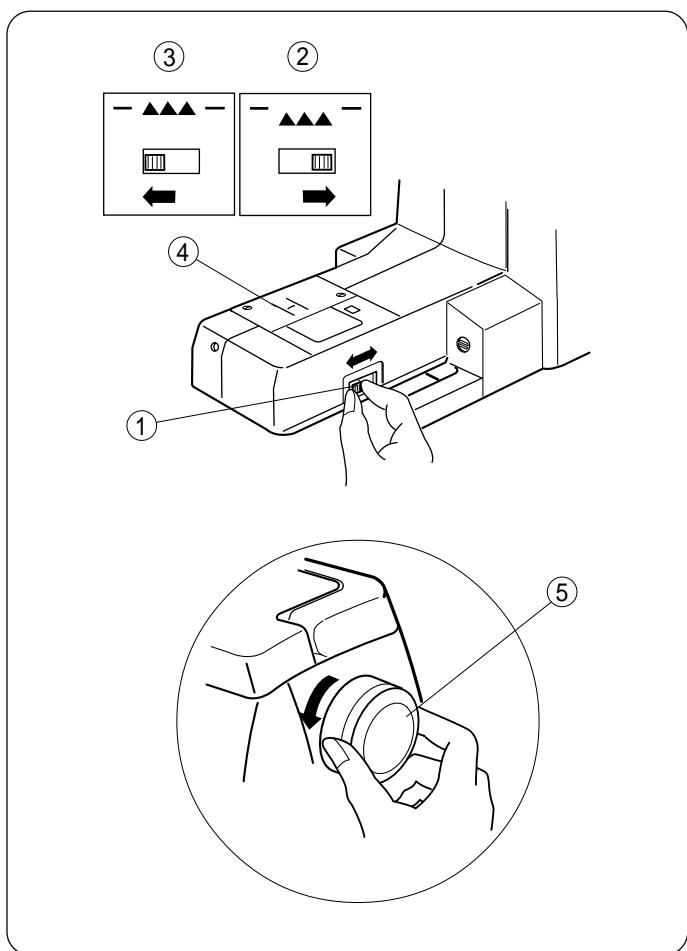

Dropping the Feed Dog

The feed dog can be lowered by the drop feed lever for sewing on buttons, manual embroidery etc. Push the drop feed lever to the right to lower the feed dog. Push the lever to the left to raise the feed dog, it will return to the up position when starting the machine.

NOTE: The feed dog should be in up position for normal sewing. Turn the handwheel toward you to check if the feed dog comes up after setting the lever in the up position.

- ① Drop feed lever
- ② Down position
- ③ Up position
- ④ Feed dog
- ⑤ Handwheel

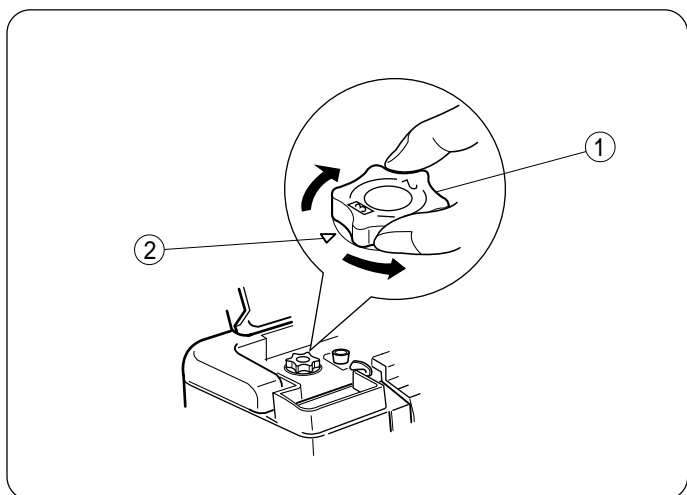

Adjusting the Foot Pressure

The foot pressure control dial should be set at "3" for regular sewing.

Reduce the pressure to "2" for appliqué, cut work, drawn work and basting.

Set the dial at "1" when sewing the extra fine fabrics.

- ① Foot pressure control dial
- ② Setting mark

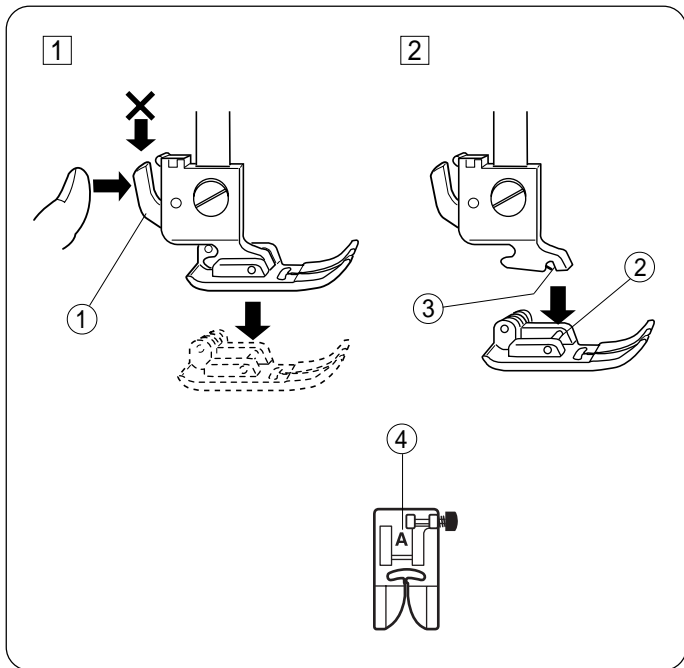

Changing the Presser Foot

WARNING: Turn OFF the power switch before changing the foot. Always use the proper foot for the selected pattern. Wrong foot can cause needle to break.

1 To snap off:

Raise the needle and presser foot. Press the black lever on the back of the foot holder and the foot will drop off.

① Lever

2 To snap on:

Place the presser foot so the pin on the foot lies just under the groove of the foot holder.

Lower the foot holder to lock the foot in place.

② Pin

③ Groove

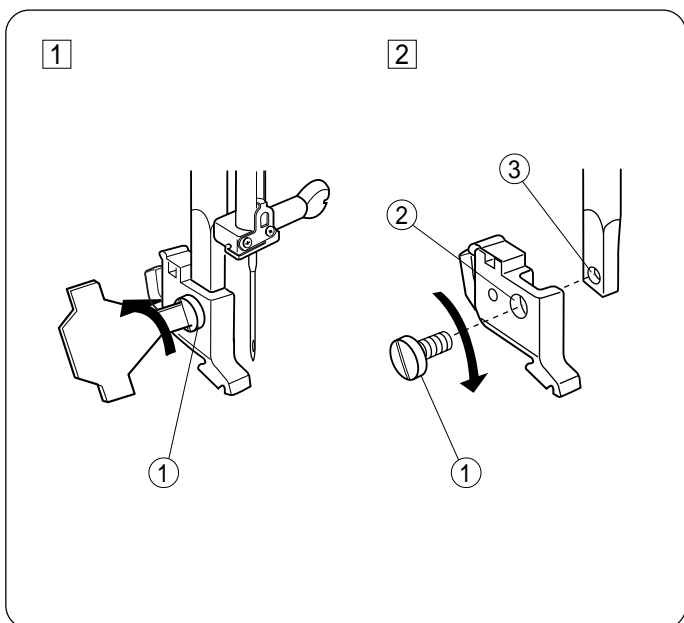

Detaching and Attaching the Foot Holder

WARNING: Turn OFF the power switch before detaching or attaching the foot holder.

1 To detach:

Raise the presser bar and turn the setscrew counter-clockwise to remove it.

Remove the foot holder.

① Setscrew

② Hole on the holder

③ Threaded hole

2 To attach:

Align the hole in the foot holder with the threaded hole on the presser bar and insert the setscrew through the hole. Tighten the setscrew by turning it clockwise.

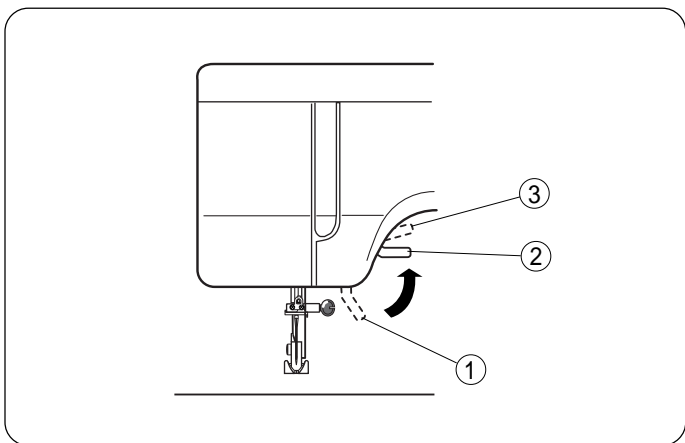

Raising and Lowering the Presser Foot

The presser foot lifter raises and lowers the presser foot. You can raise it about 0.6 cm (1/4") higher than the normal up position for easy removal of the presser foot, or to help you to place thick fabric under the foot.

- ① Lowered position
- ② Normal up position
- ③ Highest position

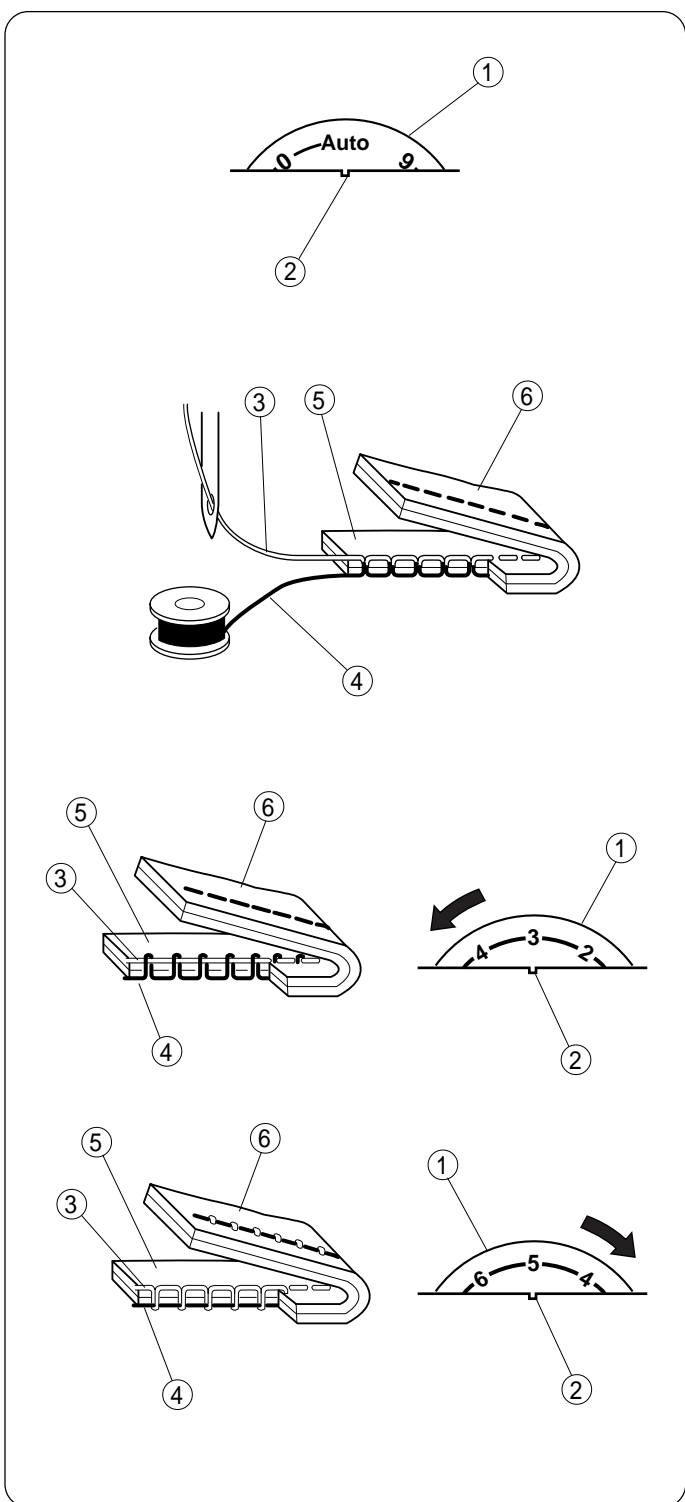

Balancing Thread Tension

• Auto tension

This machine features the Auto setting in the tension control, which covers wide range of sewing condition. Set the tension control dial at "Auto" for general sewing, unless specifically indicated in this manual.

Correct tension:

The ideal straight stitch has threads locked between two layers of fabric.

For an ideal zigzag stitch, the bobbin thread does not show on the right side of the fabric, and the needle thread shows slightly on the wrong side of the fabric.

- ① Tension control dial
- ② Setting mark
- ③ Needle thread
- ④ Bobbin thread
- ⑤ Right side of the fabric
- ⑥ Wrong side of the fabric

• Manual tension adjustment

Manual tension adjustment may be needed depending on the sewing materials, layers of fabric and other sewing conditions.

Needle thread tension is too tight:

The bobbin thread will appear on the right side of the fabric.

Loosen the needle thread tension by moving the dial to a lower number.

Needle thread tension is too loose:

The needle thread will appear on the wrong side of the fabric.

Tighten the needle thread tension by moving the dial to a higher number.

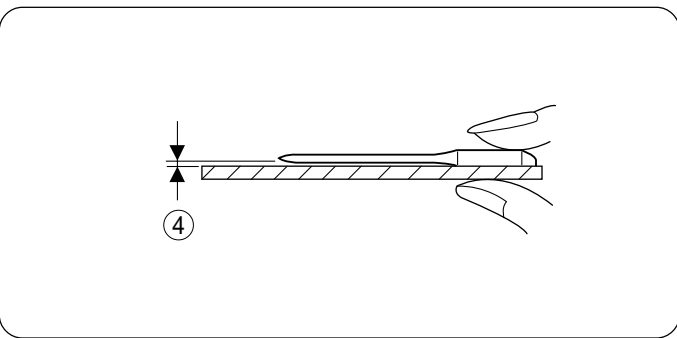
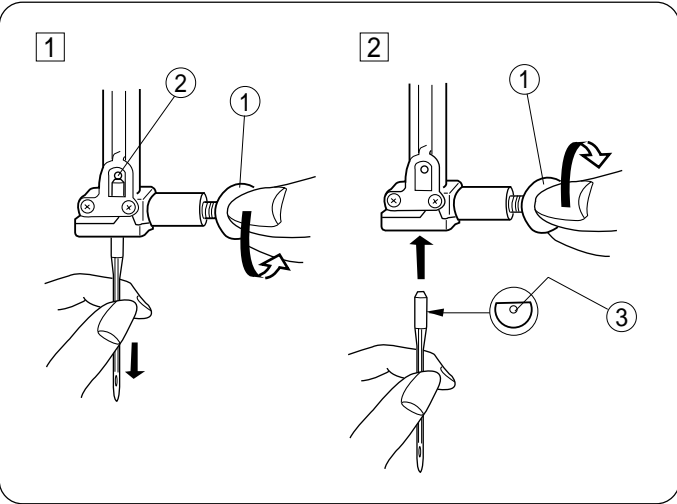

Changing the Needles

WARNING: Turn OFF the power switch before changing the needle.

- 1 Loosen the needle clamp screw and pull out the needle.
Insert a new needle into the needle clamp with the flat side facing back.
- 2 Push the needle up against the stopper pin and tighten the needle clamp screw firmly.

- ① Needle clamp screw
- ② Stopper pin
- ③ Flat side

To check the needle:

Place the flat side of the needle onto something flat (needle plate, glass etc)

The clearance between the needle and the flat surface should be consistent.

WARNING: Never use a bent or blunt needle, which can cause it to break.

- ④ Clearance

Selecting Threads and Needles

Fabric		Thread	Needle
Light	Lawn Georgette Tricot Wool, Synthetic	Silk #80-100 Cotton #80-100 Synthetic #80-100	#9/65-11/75
Medium	Cotton, Synthetic Fine jersey Wool	Silk #50 Cotton #60-80 Synthetic #50-80 Cotton #50	#11/75-14/90 #14/90
	Denim Jersey Coating Quilting	Silk #50 Cotton #40-50 Synthetic #40-50 Silk #30	#14/90-16/100 #16/100

- * For general sewing, use needle size #11/75 or #14/90.
- * A fine thread and needle should be used for sewing lightweight fabrics, so the fabric will not be marred. Heavy fabrics require a needle large enough to pierce the fabric without fraying the needle thread.
- * Always test the thread and needle size on a small piece of fabric, which will be used for actual sewing.
- * In general, use same thread for needle and bobbin.
- * When sewing stretch, very fine fabrics and synthetics, use a BLUE TIPPED needle. The blue tipped needle effectively prevents skipped stitches.

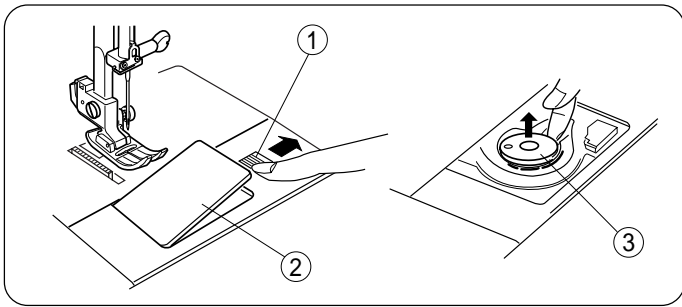

Winding the Bobbin

• Removing the bobbin

Slide the hook cover release button to the right, and remove the hook cover.

Take the bobbin out.

- ① Hook cover release button
- ② Hook cover
- ③ Bobbin

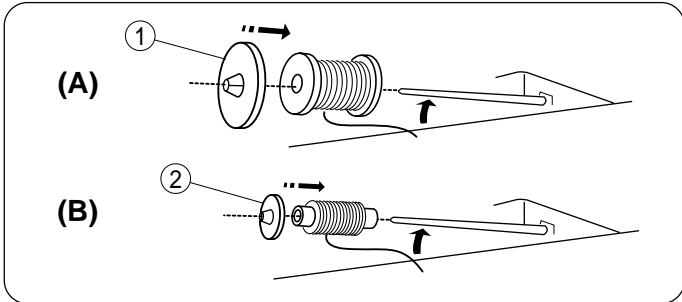

Setting the spool of thread

Place the spool of thread on the spool pin with the thread coming off the spool as shown.

(A) For an ordinary spool: Use the large spool holder.

- ① Large spool holder

(B) For a narrow or small spool: Use the small spool holder.

- ② Small spool holder

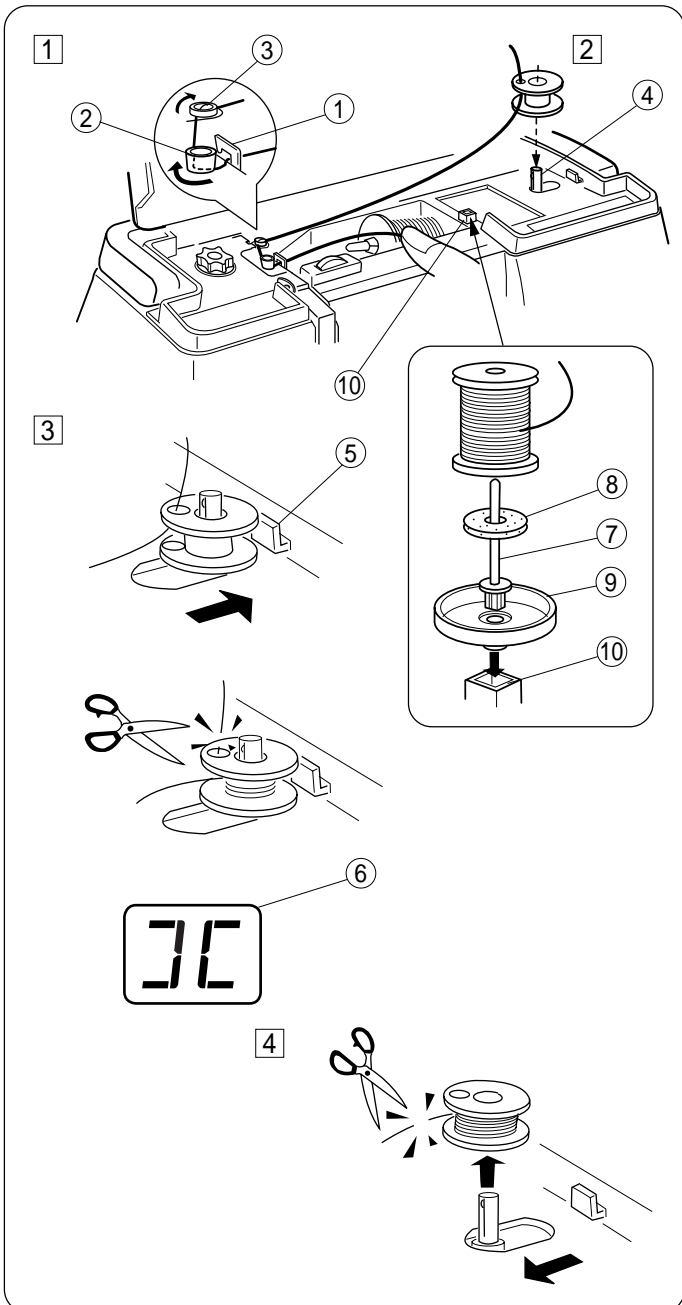

• Winding the bobbin

NOTE: Set the speed control lever at (>>>) for bobbin winding.

Guide the thread around the bobbin winder thread guide.

① Guide the thread around the thread guides (A), (B) and bobbin winder thread guide.

② Insert the thread through the hole on the bobbin, threading from the inside to the outside. Put the bobbin on the bobbin winder spindle.

- ① Thread guide (A)
- ② Thread guide (B)
- ③ Bobbin winder thread guide
- ④ Bobbin winder spindle

③ Push the bobbin winder spindle to the right.

With the free end of the thread held in your hand, depress the foot control. Stop the machine when the bobbin has made a few turns, and cut the thread close to the hole on the bobbin.

NOTE: The LED display shows “7C” when shifting the spindle to the right.

- ⑤ Bobbin winder stopper
- ⑥ LED display

④ Depress the foot control again. When the bobbin is fully wound, it will stop automatically. Return the bobbin to its original position by moving the spindle to the left, and cut the thread as shown.

NOTE: Do not move the bobbin winder spindle while the machine is running.

Additional spool pin

Insert the additional spool pin and spool stand into the hole on the machine. Place the felt and spool on the spool pin as shown.

- ⑦ Additional spool pin
- ⑧ Felt
- ⑨ Spool stand
- ⑩ Hole for the additional spool pin

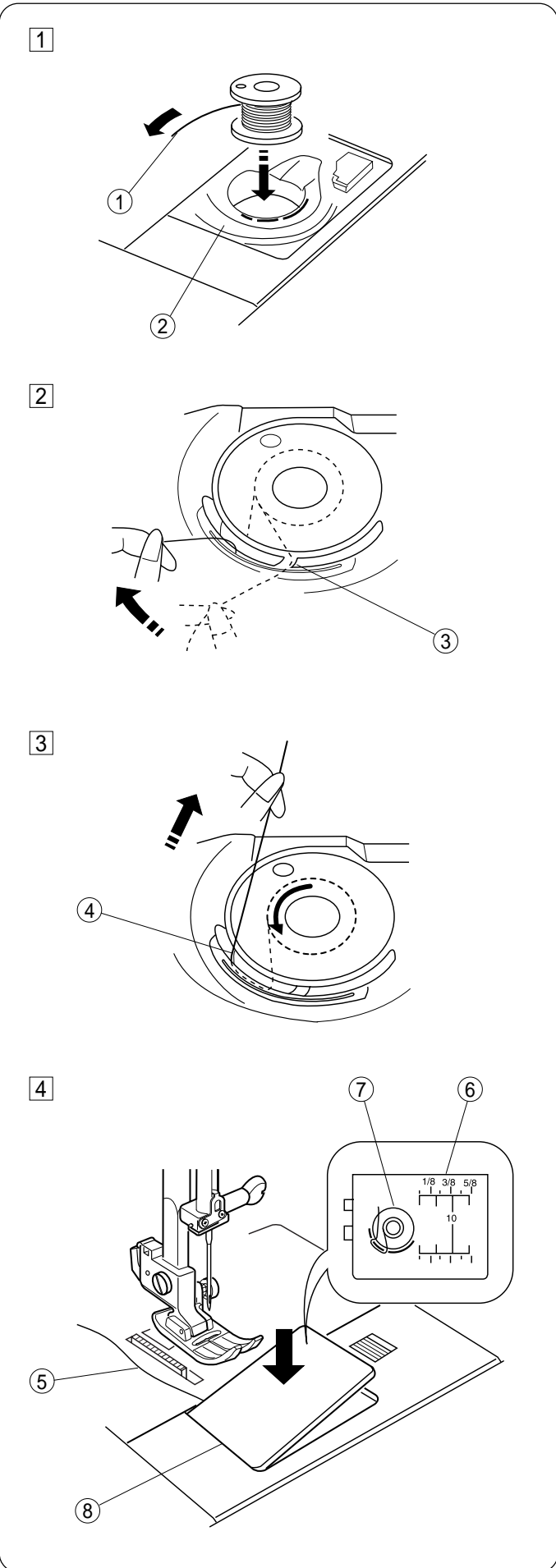

• Inserting the bobbin

1 Place the bobbin in the bobbin holder with the thread running counter-clockwise.

- ① End of the thread
- ② Bobbin holder

2 Guide the thread into the notch **A** on the front side of the bobbin holder. Draw the thread to the left sliding it between the tension spring blades.

- ③ Notch A

3 Continue to draw the thread lightly through the tension blades until it slips into notch **B**.

- ④ Notch B

Draw the thread to the back.

The bobbin should turn counterclockwise when pulling the thread.

4 Pull out about 10 cm (4") of thread and attach the hook cover plate.

- ⑤ Bobbin thread
- ⑥ Hook cover plate
- ⑦ Threading chart
- ⑧ Align left edge of the hook cover.

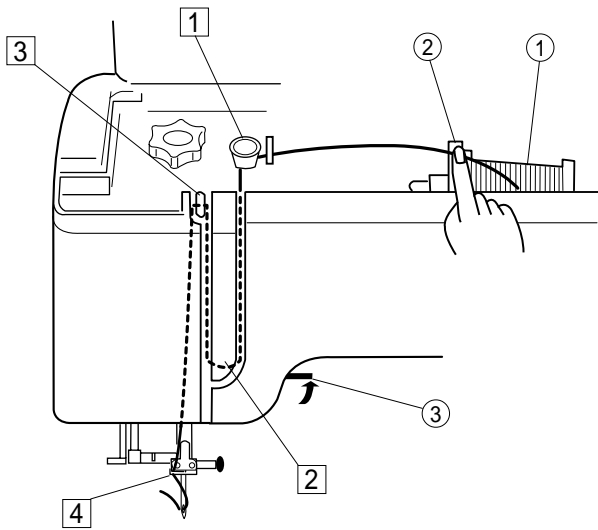

Threading the Machine

• Threading the needle thread

Raise the presser foot.

Press the needle Up/Down button twice to bring the take-up lever to its highest position then turn off the power switch.

- ① Spool of thread
- ② Spool holder
- ③ Presser foot lifter

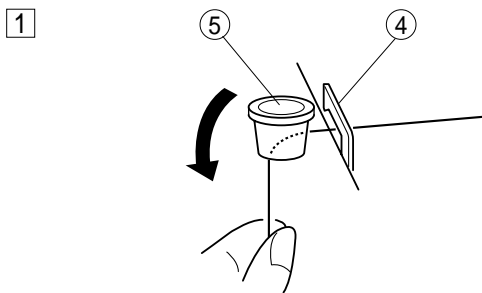

- ① Draw the end of the thread with your left hand and pass it under the thread guide (A) then hook around the thread guide (B) while holding the spool with your right hand.

- ④ Tread guide (A)
- ⑤ Thread guide (B)

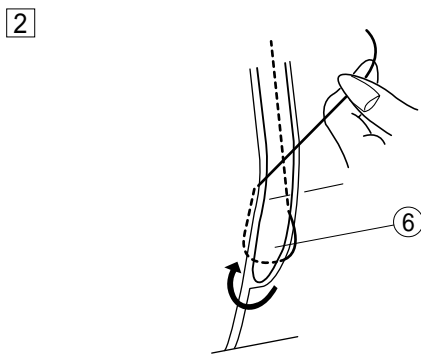

- ② Draw the end of the thread down around the thread guide plate and draw it up.

- ⑥ Thread guide plate

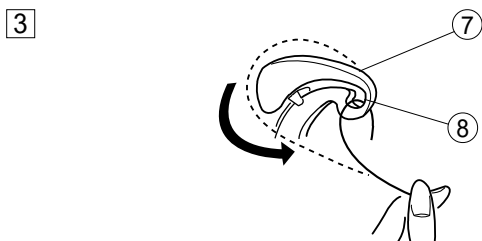

- ③ Firmly draw up the thread up to the take-up lever, and down into the eye of the thread take-up lever from the right to left.

- ⑦ Thread take-up lever
- ⑧ Eye of the thread take-up lever

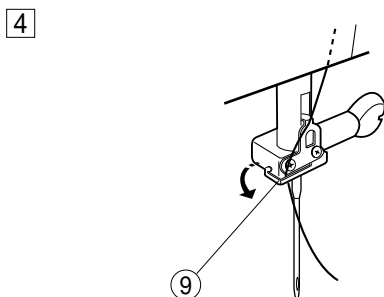

- ④ Slip the thread in the needle bar thread guide on the left.

- ⑨ Needle bar thread guide

NOTE: Refer to page 14 for the automatic needle threader.

Automatic Needle Threader

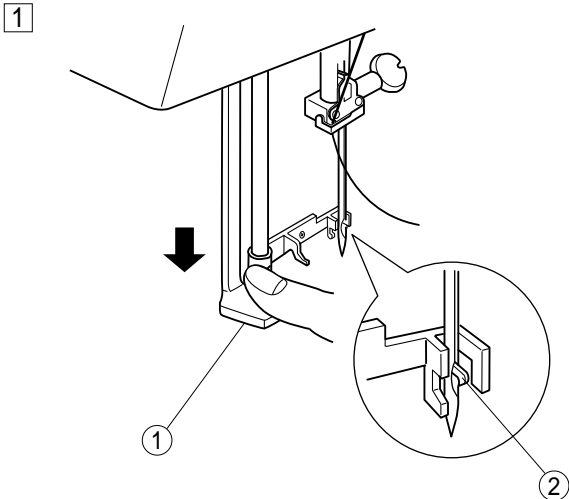

- 1 Raise the needle to its highest position by pressing the needle Up/Down button twice.
Raise the presser foot.
Depress the needle threader knob as far as it will go.
The hook comes out through the needle eye from behind.

- ① Needle threader knob
- ② Hook

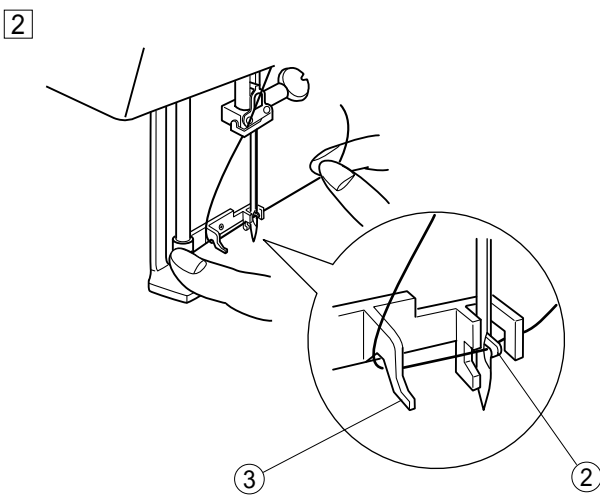

- 2 Draw the thread down around the threader guide and under the hook.

- ③ Threader guide

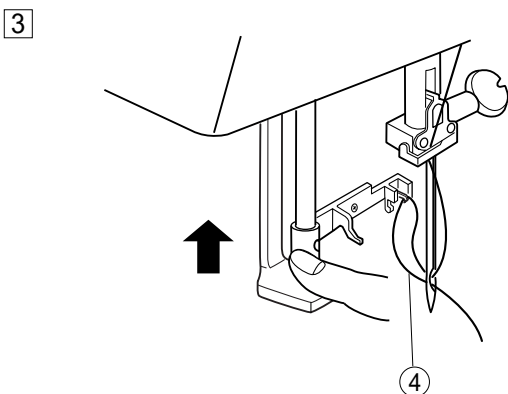

- 3 Release the threader knob slowly while holding the thread end with your hand. A loop of the thread is pulled up through the needle eye.

- ④ Thread end

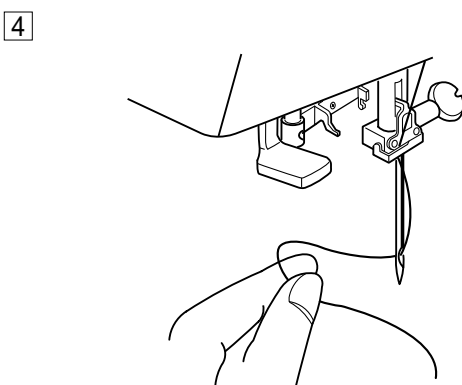

- 4 Remove the loop from the threader and pull out the thread end from the needle eye.

NOTES: Set the needle at the center needle drop position when using the automatic needle threader.
The automatic threader works well with the threads #50-100 and needles #11-16, the blue tipped needle as well.

Drawing Up Bobbin Thread

1

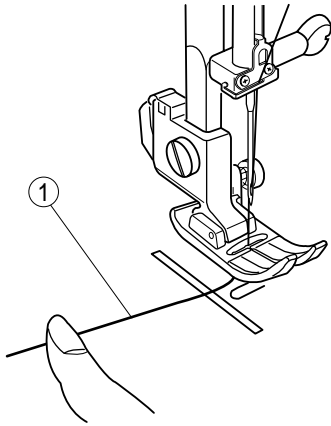

1 Raise the presser foot and hold the needle thread with your fingers.

① Needle thread

2

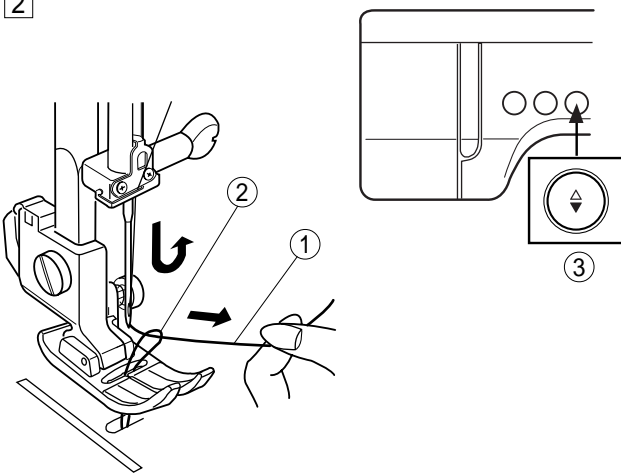

2 Press the needle Up/Down button twice to raise the needle to its highest position. Pull the needle thread to pick up a loop of the bobbin thread.

① Needle thread

② Bobbin thread

③ Needle Up/Down button

3

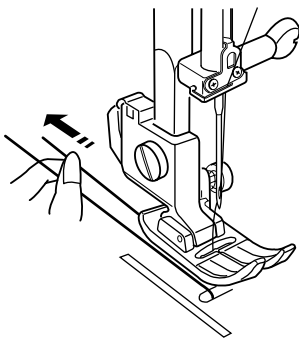

3 Draw 10 cm (4") of both threads to the back under the presser foot.

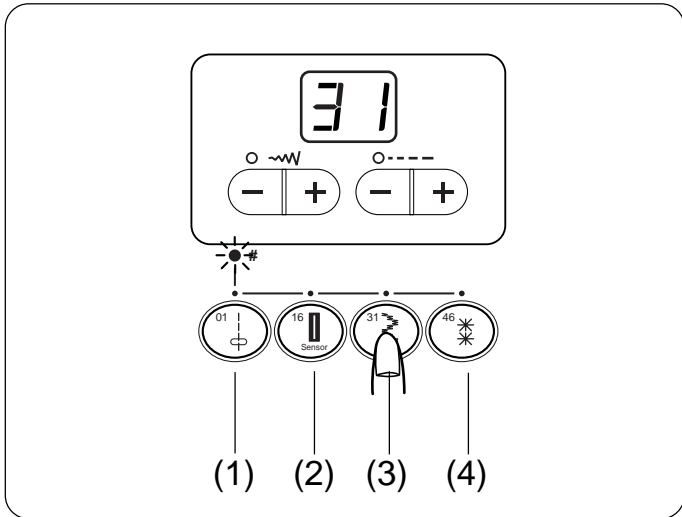

Selecting the Stitch Pattern

Press the pattern selection key until pattern number of the desired stitch is shown in the LED display.

The key (1) on the left selects patterns #01 to #15.

The key (2) second from the left selects patterns #16 to #30.

The third key (3) selects patterns #31 to #45.

The last key (4) selects patterns #46 to #60.

NOTE: Raise the needle above the fabric when selecting the stitch pattern.

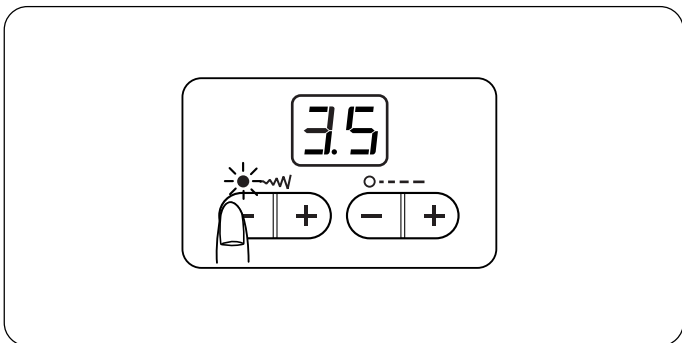

Adjusting the Stitch Width

Press the plus (+) or minus (-) key on the left to change the stitch width.

The LED display will show the default value of the selected pattern when you press the plus or minus key once.

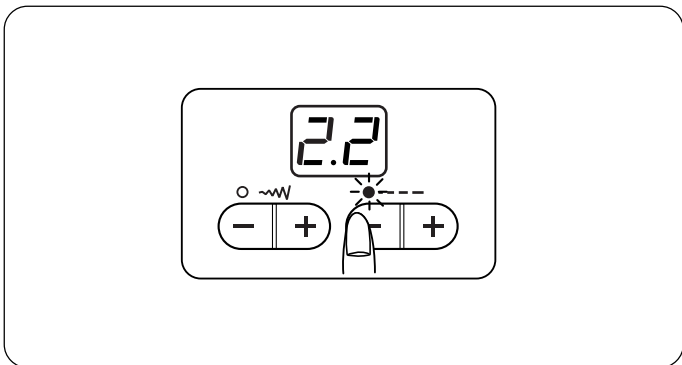

Adjusting the Stitch Length

Press the plus (+) or minus (-) key on the right to change the stitch length.

The LED display will show the default value of the selected pattern when you press the plus or minus key once.

UTILITY STITCHES

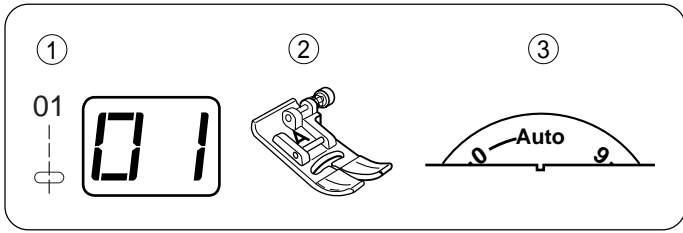

Straight Stitch

Machine setting

- ① Pattern #1
- ② Foot A: Zigzag foot
- ③ Thread tension Auto

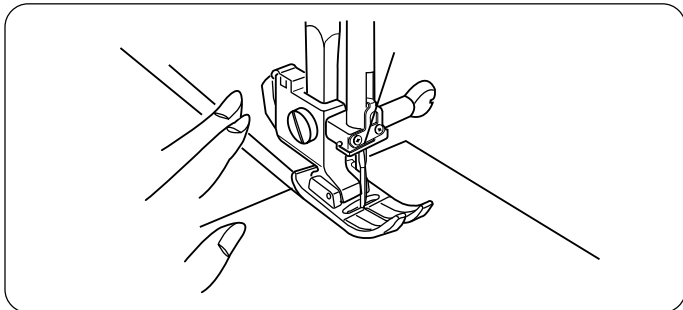

• Starting to sew

Raise the presser foot and place the fabric on the machine.
Lower the needle into the fabric where you want to start.
Lower the presser foot and start sewing.

NOTE: To fasten the beginning of the seams, sew several reverse stitches by pressing the reverse stitch button, or use pattern #02 (Lock-a-Matic stitch).

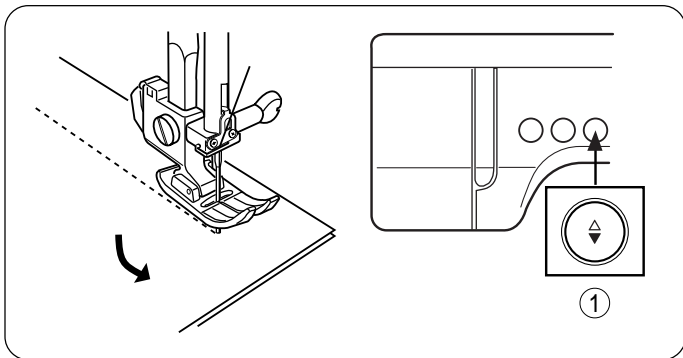

• Changing sewing direction

Stop the machine and bring the needle down into the fabrics by pressing the needle Up/Down button.
Raise the presser foot.
Pivot the fabric around the needle to change the sewing direction as desired.
Lower the presser foot and start sewing in a new direction.

- ① Needle Up/Down button

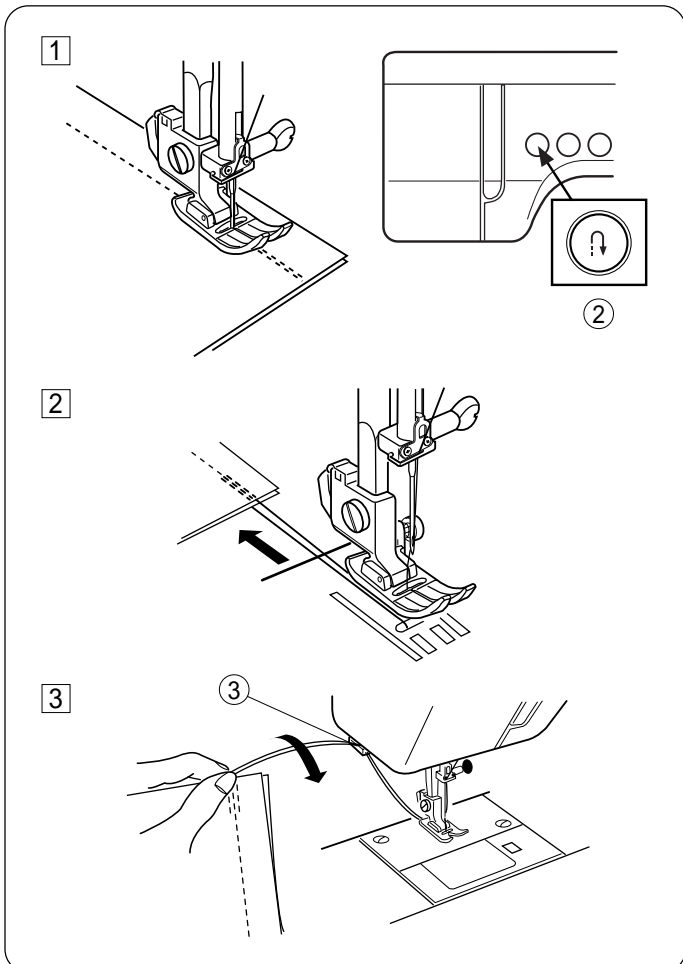

• Fastening the seam

- ① Sew several stitches in reverse by pressing the reverse stitch button to fasten the end of seam.

NOTE: If you use pattern #02 (Lock-a-Matic stitch), press the reverse stitch button once and the machine will sew in reverse and stop automatically.

- ② Revers stitch button

- ② Raise the presser foot and pull the fabric to the rear.

- ③ Draw the threads up and into the thread cutter. The threads are cut at the proper length for starting the next seam.

- ③ Thread cutter

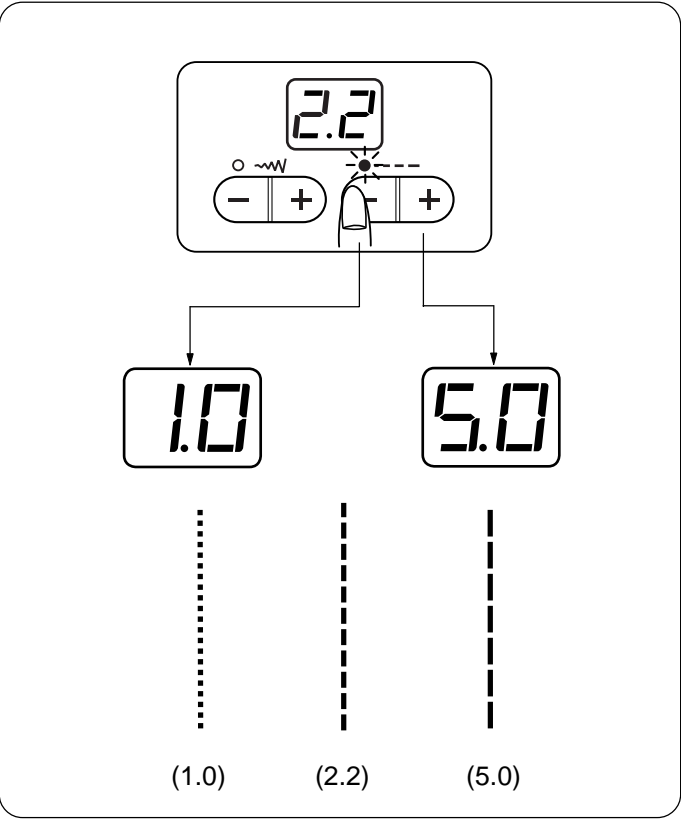

• Adjusting the Stitch Length

The LED display shows “ 2.2 ” (default setting) when the plus or minus key is pressed once.
 Press the plus (+) key to increase stitch length.
 Press the minus (-) key to decrease stitch length.
 The stitch length can be varied from 0.0 to 5.0.

NOTE: Reverse stitch length cannot be set longer than 2.5.

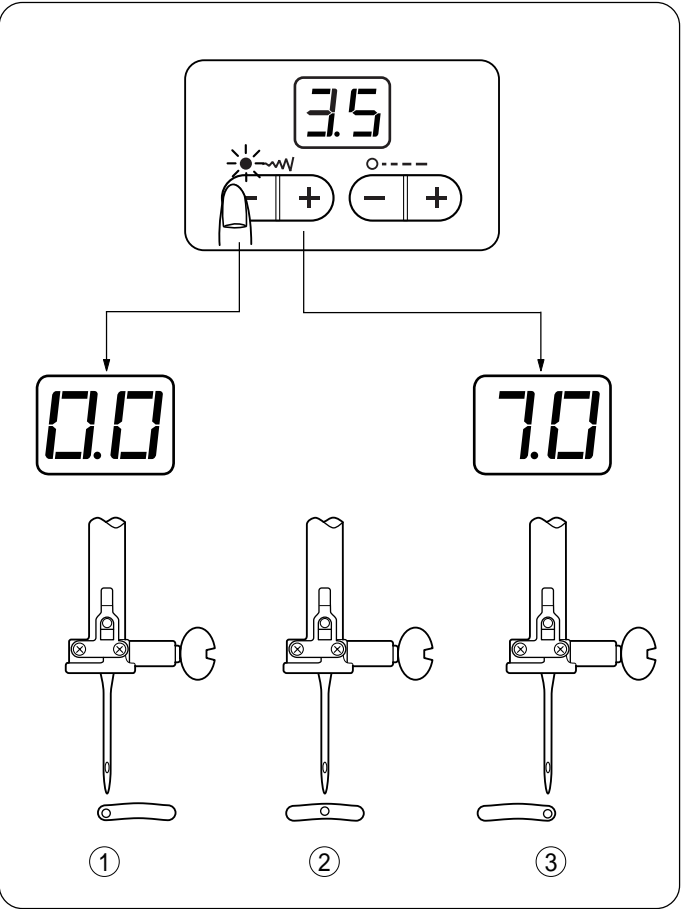

• Changing the needle drop position

You can change the needle drop position of straight stitching, i.e. patterns #01-03 and #06-09.

The LED display shows “ 3.5 ” (default setting), which represents the center needle position when the plus or minus key is pressed once.

Press the plus (+) key to move the needle to the right.
 Press the minus (-) key to move the needle to the left.

- ① Left needle position
- ② Center needle position
- ③ Right needle position

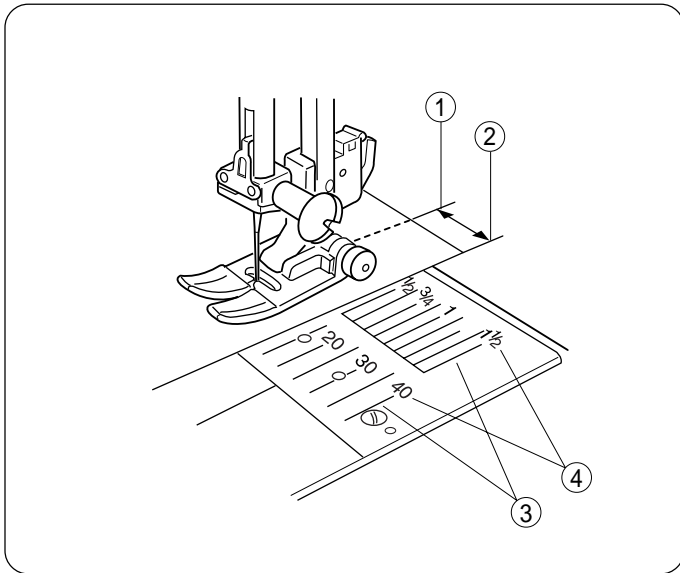

• Using the seam guide lines

The seam guides on the needle plate and hook cover help you to measure seam allowance.

NOTE: The number indicates the distance from the center needle position.

Number	10	20	30	40	1/2	3/4	1	1 1/2
Distance (cm)	1.0	2.0	3.0	4.0	1.3	1.9	2.5	3.8

- ① Center needle position
- ② Edge of the fabric
- ③ Guide lines
- ④ Numbers

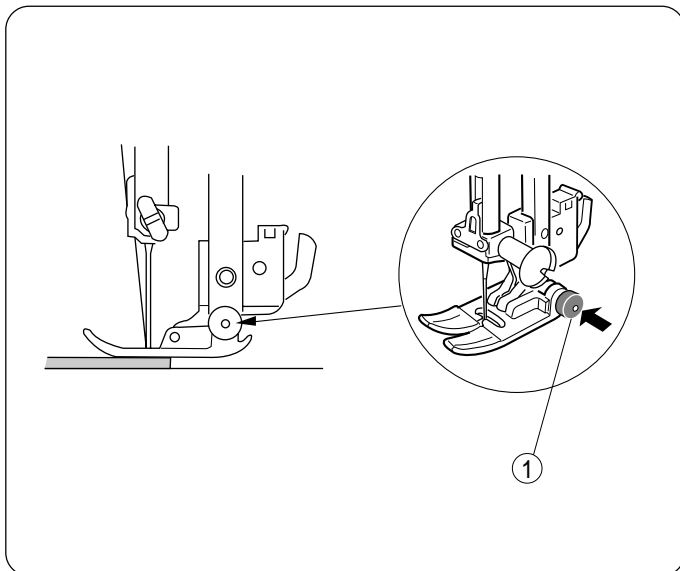

• Sewing from the edge of thick fabric

The black button locks the zigzag foot to avoid slipping when sewing from the extreme edge or sewing across the hem.

Lower the needle into the fabric at the point to start sewing.

Lower the foot while pushing the black button in.

The foot is locked in the horizontal position.

The foot will be unlocked automatically after sewing several stitches.

- ① Black button

Variety of Straight Stitching

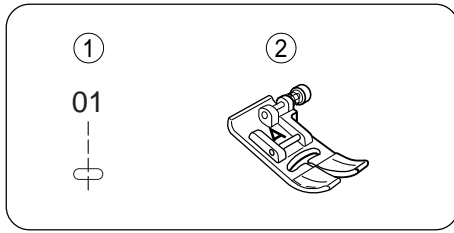

① Pattern #01 Straight stitch ② Foot A: Zigzag foot
For seaming garments, zipper application and more.

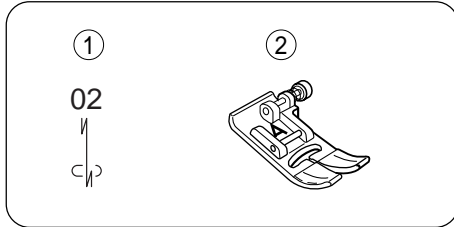

① Pattern #02 Lock-a-Matic stitch ② Foot A: Zigzag foot
Seaming with auto reverse stitches at the beginning and end
Press the reverse stitch button once, the machine will sew the reverse stitches and stop automatically.

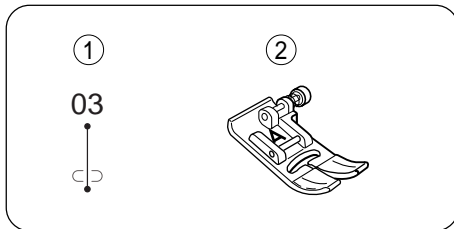

① Pattern #03 Locking stitch ② Foot A: Zigzag foot
Seaming with auto locking stitches at the beginning and end
Press the reverse stitch button once, the machine will lock the stitches and stop automatically.

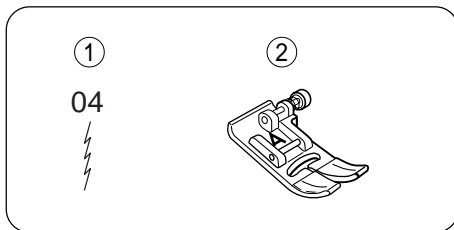

① Pattern #04 Stretch stitch ② Foot A: Zigzag foot
For seaming stretch fabrics that tend to pucker
The seam can be opened flat.

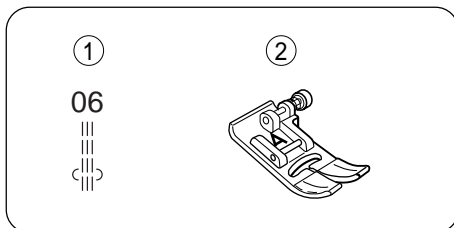

① Pattern #06 Straight stretch stitch ② Foot A: Zigzag foot
Strong and durable stitch recommended for stretch fabrics and areas to reinforce.

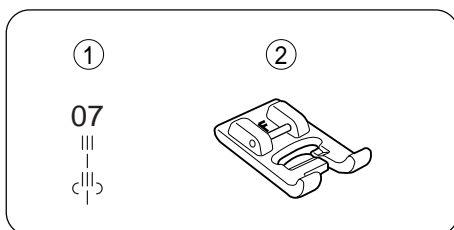

① Pattern #07 Sculpture stitch ② Foot F: Satin stitch foot
For top stitching and outlining designs.
Sew slowly at the corners.

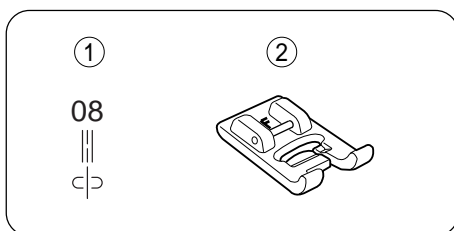

① Pattern #08 Stretch stitch ② Foot F: Satin stitch foot
For top stitching and quilting.

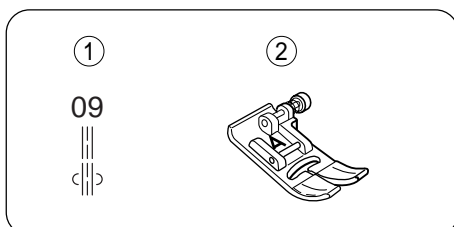

① Pattern #09 Saddle stitch ② Foot A: Zigzag foot
Long straight stretch stitch, similar to hand stitches.

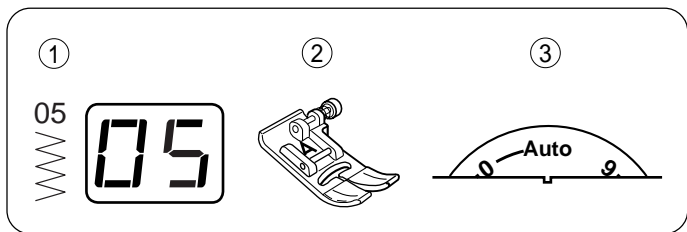

Basic Zigzag Stitch

Machine setting

- | | |
|------------------|----------------|
| ① Pattern | #05 |
| ② Foot | A: Zigzag foot |
| ③ Thread tension | Auto |

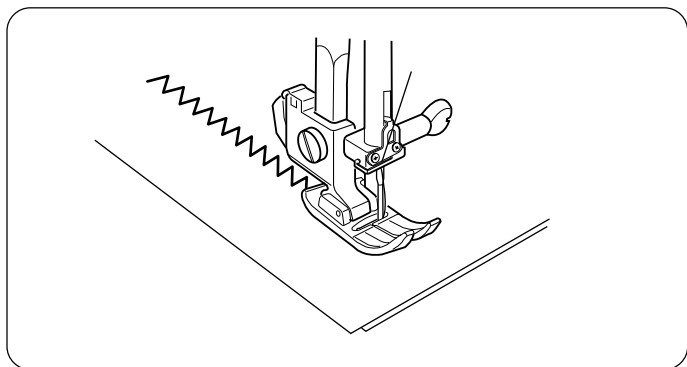

Zigzag stitch is one of the most useful and versatile stitches.

It is used for overcasting, mending, appliqué also used as a decorative stitch.

NOTE: Use an interface when sewing on the stretch fabric such as knit, jersey or tricot.

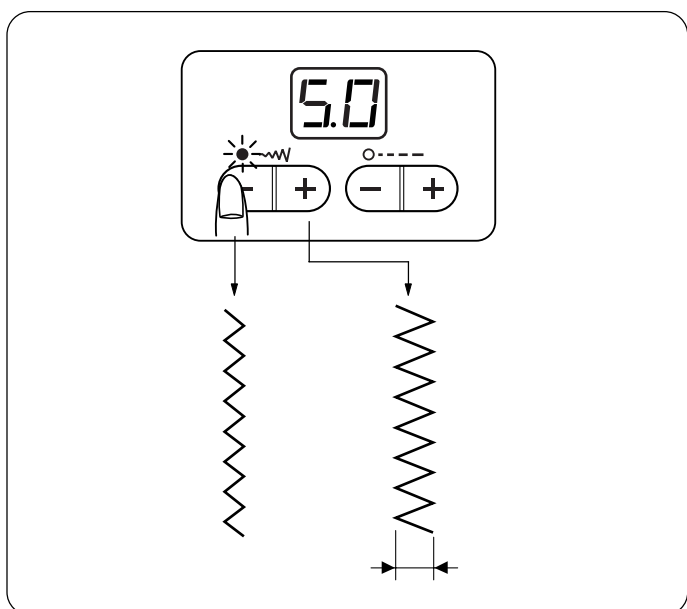

• Adjusting the stitch width

The LED display shows “ 5.0 ” (default setting) when the plus or minus key is pressed once.

Press the plus (+) key to increase the stitch width.

Press the minus (–) key to decrease the stitch width.

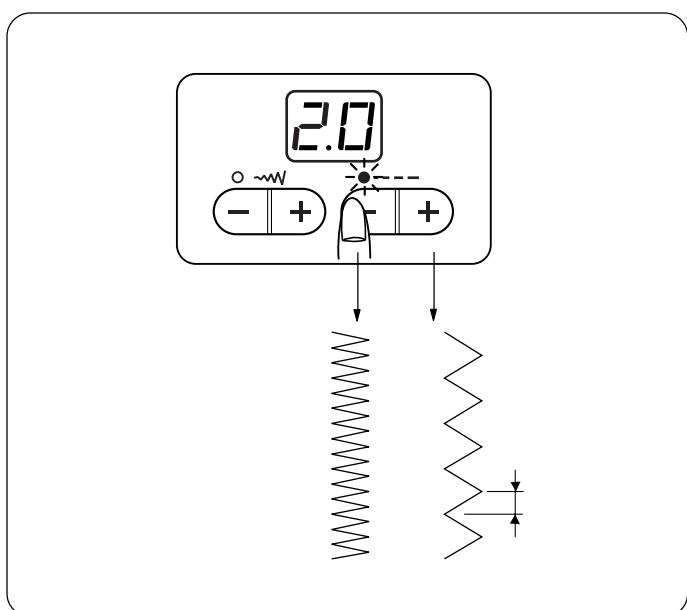

• Adjusting the stitch length

The LED display shows “ 2.2 ” (default setting) when the plus or minus key is pressed once.

Press the plus (+) key to increase stitch length.

Press the minus (–) key to decrease stitch length.

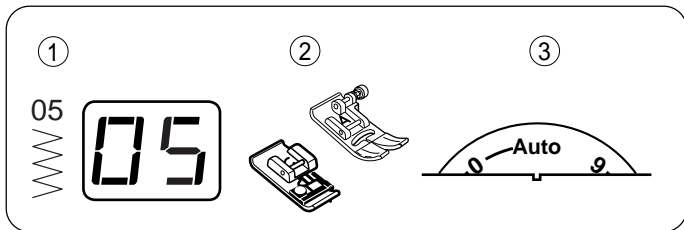

Overcasting

• Zigzag stitch

Machine setting

- | | |
|------------------|---------------------|
| ① Pattern | #05 |
| ② Foot | C: Overcasting foot |
| ③ Thread tension | Auto |

CAUTION: Do not set the stitch width less than 5 when using the overcasting foot to prevent the needle from hitting the wires on the foot.

Place the raw edge of the fabric next to the guide of the foot and start sewing.

- ① Guide

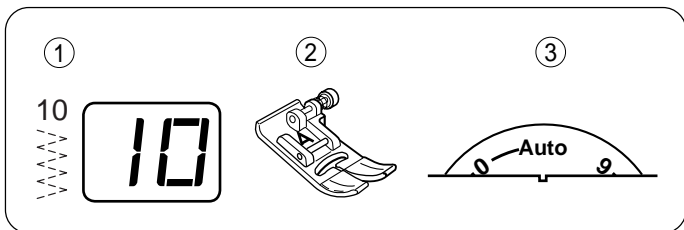
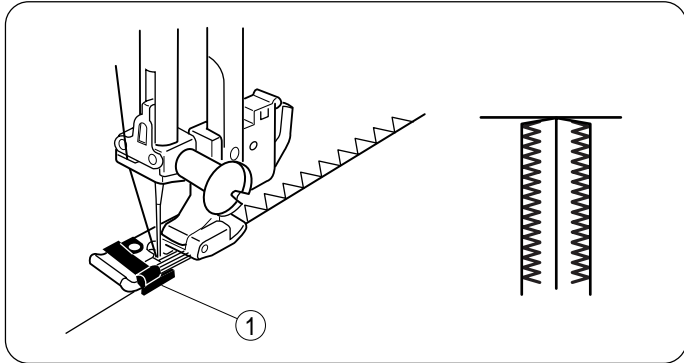

• Multiple zigzag stitch (Tricot stitch)

Machine setting

- | | |
|------------------|----------------|
| ① Pattern | #10 |
| ② Foot | A: Zigzag foot |
| ③ Thread tension | Auto |

This stitch is used to finish a raw edge of synthetics and other stretch fabrics that tend to pucker. Sew along the fabric edge leaving an enough seam allowance.

After sewing, trim off the seam allowance closer to the stitches as shown.

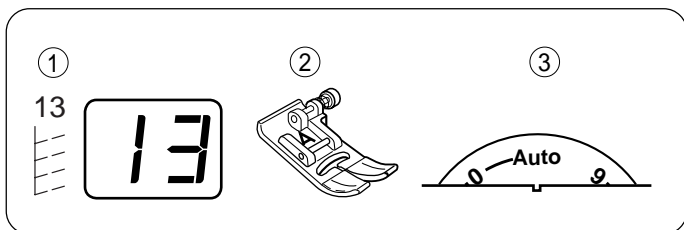
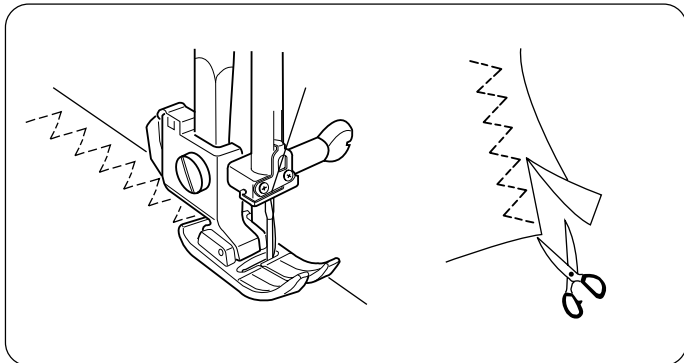

• Knit stitch

Machine setting

- | | |
|------------------|----------------|
| ① Pattern | #13 |
| ② Foot | A: Zigzag foot |
| ③ Thread tension | Auto |

This stitch is used to finish a raw edge of knit and other stretch fabrics. Sew along the fabric edge leaving an enough seam allowance.

After sewing, trim off the seam allowance closer to the stitches as shown.

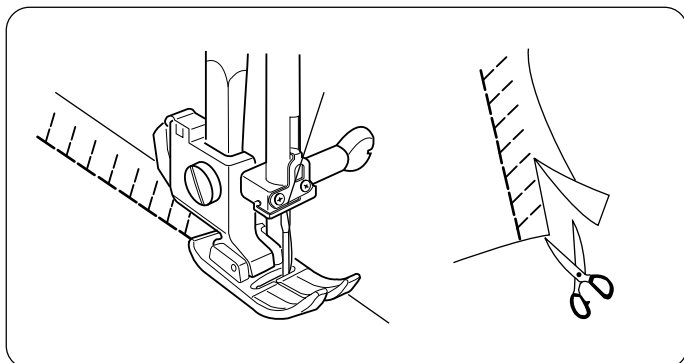

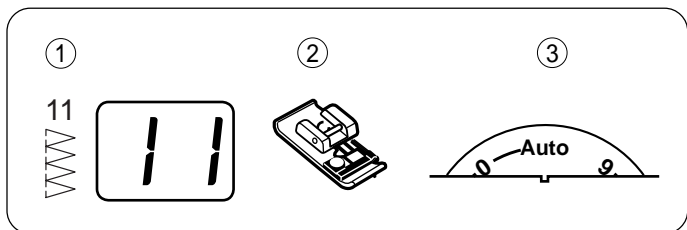

• Overedge stitch

Machine setting

- ① Pattern #11
- ② Foot C: Overcasting foot
- ③ Thread tension Auto

CAUTION: Do not set the stitch width less than 5 when using the overedge foot to prevent the needle from hitting the wires on the foot.

This stitch overcasts and seams the raw edge at the same time, it prevents fraying.

Sew while guiding the fabric edge along the guide on the foot.

- ① Guide
- ② Edge of the fabric

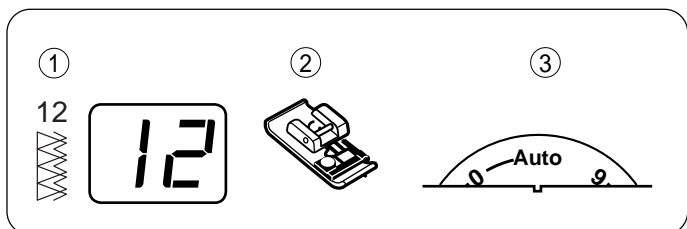
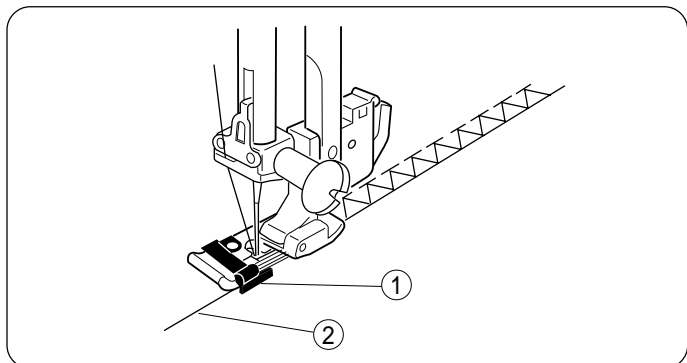

• Serging stitch

Machine setting

- ① Pattern #12
- ② Foot C: Overcasting foot
- ③ Thread tension Auto

CAUTION: Do not set the stitch width less than 5 when using the overedge foot to prevent the needle from hitting the wires on the foot.

This stitch is used for overcasting medium to heavy weight fabrics.

Sew while guiding the fabric edge along the guide on the foot.

- ① Guide
- ② Edge of the fabric

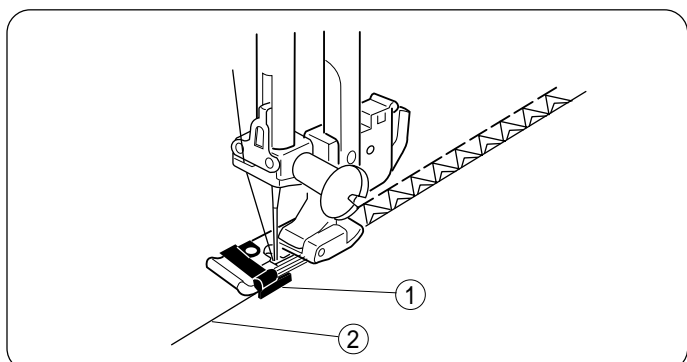

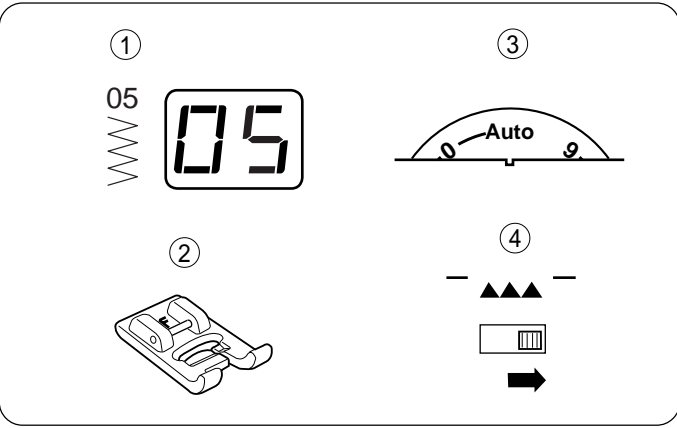

Sewing on Buttons

Machine setting

① Pattern	#05
② Foot	F: Satin stitch foot
③ Thread tension	Auto
④ Feed dog	Dropped

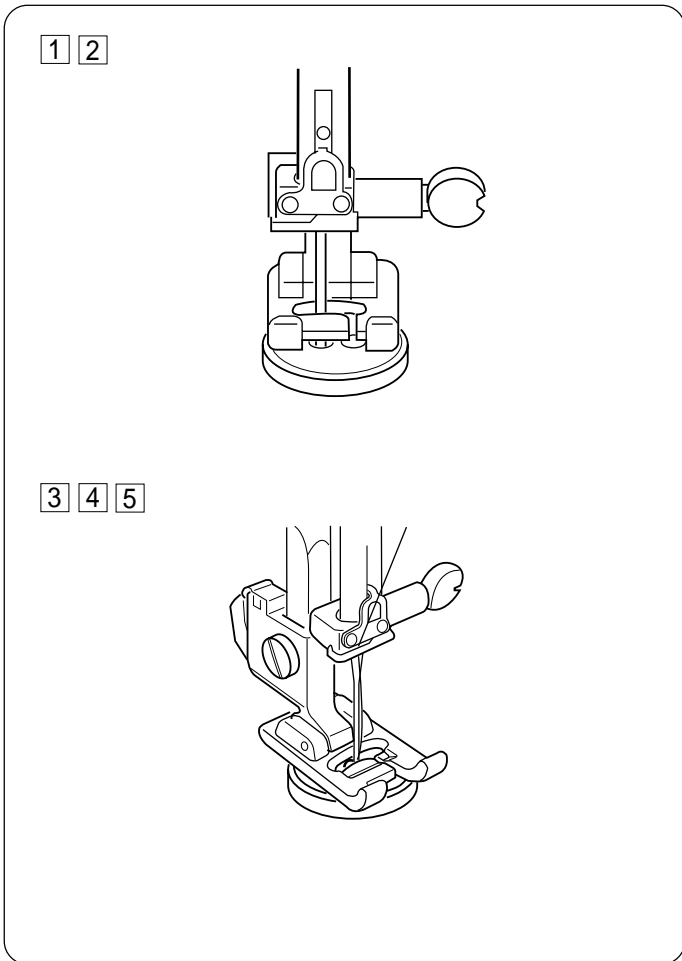

- ① Unthread the needle. Adjust the stitch width to match the needle swing with the span of the holes on the button, by pressing the plus (+) or minus (-) key.
 - ② Rethread the needle and lower the presser foot to hold the button in place.
 - ③ Turn the handwheel toward you to check if the needle enters both left and right holes on the button.
 - ④ Depress the foot control to sew 10 stitches and stop the machine.
 - ⑤ Raise the foot and draw out the fabric, and trim both needle and bobbin threads at the beginning of stitches but leaving 20 cm (8") tails at the end.
 - ⑥ Pull the bobbin thread to pick the needle thread out to the wrong side of the fabric and tie them together.
- * After finish sewing, raise the feed dog by shifting the drop feed lever to the original position.

Automatic Buttonhole

Variety of buttonholes

#16 Square buttonhole (Sensor buttonhole):

Widely used for medium to heavy weight fabrics. The buttonhole size is automatically determined by placing a button on the back of the automatic buttonhole foot.

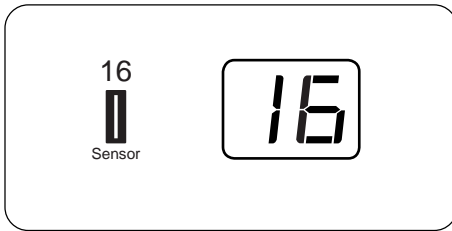

#17 Square buttonhole (Auto buttonhole):

Similar to the sensor buttonhole, but you can set the buttonhole length as desired and memorize it to repeat the same size buttonholes.

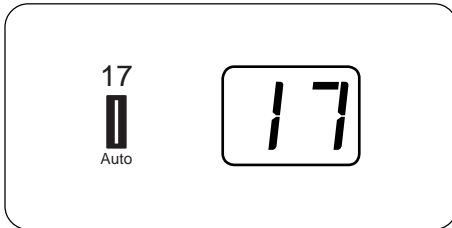

#18 Round end buttonhole:

For fine to medium fabrics, such as blouses and children's garments.



#19 Keyhole buttonhole:

For medium to heavy weight fabrics, such as jackets and overcoats.

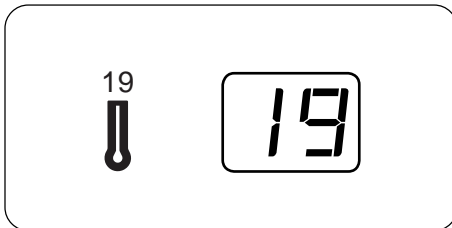

#20 Knit buttonhole:

For stretch fabrics such as knits. Also used as a decorative buttonhole.

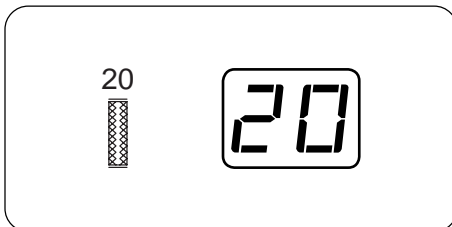

#21 Fine fabric buttonhole:

Suitable for fine and delicate fabrics such as a fine silk. Both ends are rounded.

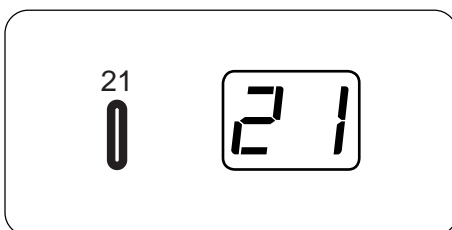

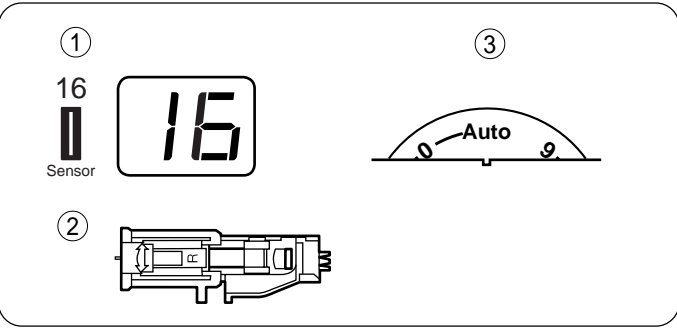

Square buttonhole

Machine setting

- ① Pattern #16
- ② Foot R: Automatic buttonhole foot
- ③ Thread tension Auto

NOTES: The size of buttonhole is automatically set by placing the button in the rear of the automatic buttonhole foot R.
 The button holder of the foot takes a button size up to 2.5 cm (1") in diameter.
 Make a test buttonhole on a scrap fabrics of the actual garment.
 Use the interfacing on the stretch fabrics.

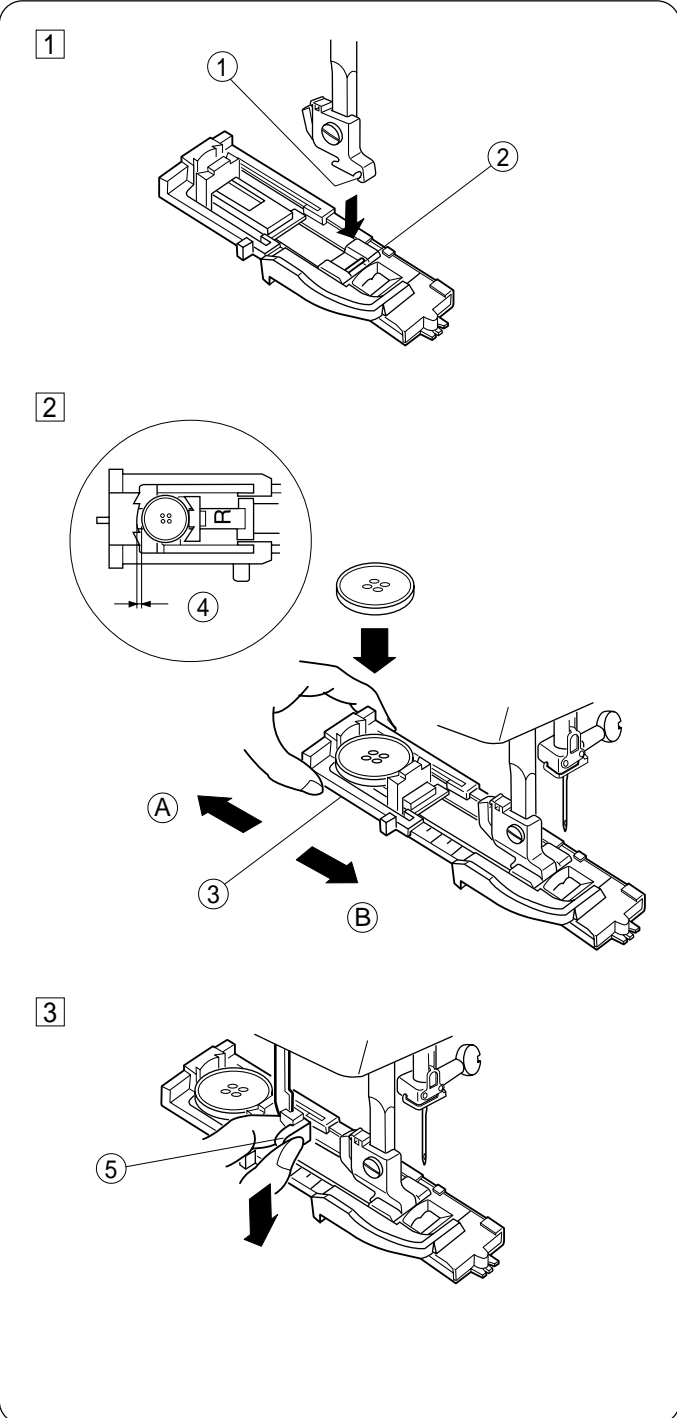

① Raise the needle by turning the handwheel. Raise the foot and place the automatic buttonhole foot with its pin just under the groove of the foot holder. Lower the presser bar to attach the foot.

- ① Groove
- ② Pin

② Pull the button holder to the back (A), and place the button in it. Push back the button holder toward you (B) to hold the button.

- ③ Button holder

NOTE: If the button is extremely thick, make a test buttonhole. If it is difficult to fit the button through the test buttonhole, lengthen the buttonhole by pulling the button holder back to create a gap.

- ④ Gap

③ Pull the buttonhole lever downward as far as it will go.

- ⑤ Buttonhole lever

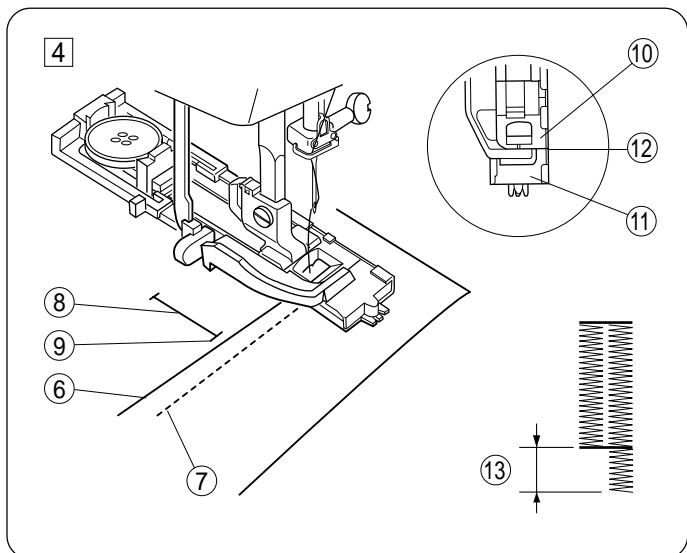

4 Raise the buttonhole foot and draw the needle thread to the left through the hole on the foot. Place the fabric under the foot and lower the needle at the starting point by turning the handwheel. Then lower the foot.

- ⑥ Needle thread
- ⑦ Bobbin thread
- ⑧ Buttonhole mark
- ⑨ Starting point

NOTE: Make sure there is no gap between the slider and spring holder, otherwise the left and right length of the buttonhole will be different.

- ⑩ Slider
- ⑪ Spring holder
- ⑫ No gap
- ⑬ Sewing gap

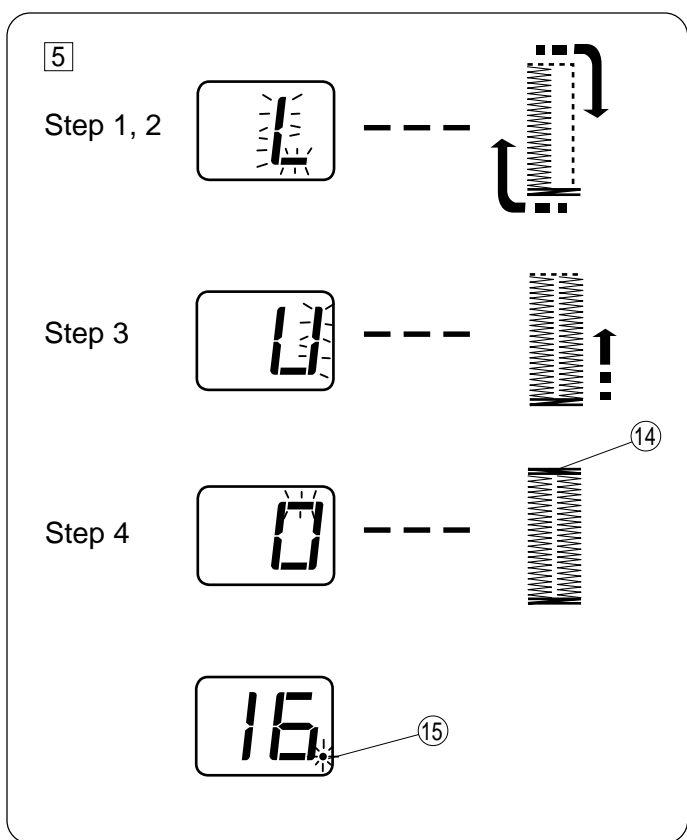

5 Depress the foot control to sew a buttonhole.

The machine will sew a buttonhole in the following order:

Step 1 and 2: Front bartack and left row.

Step 3: Right row.

Step 4: Back bartack and locking stitches at the end
LED shows each sewing step and a dot will blink when the buttonhole is finished.

- ⑭ End point
- ⑮ Dot

NOTES: You can sew another layer of the buttonhole over the previous stitching (see page 28). If you want to select other pattern or buttonhole, raise the presser foot then select the desired pattern.

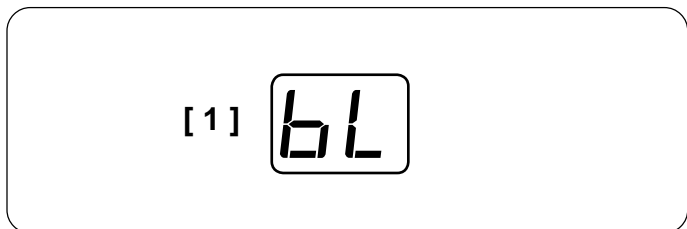

[1] If you start buttonhole sewing without lowering the buttonhole lever, the LED display shows "bL".

Lower the buttonhole lever and restart the machine.



[2] If you select the other pattern without raising the presser foot or buttonhole lever, the LED display shows "UP". Select the other pattern after raising the foot and buttonhole lever.

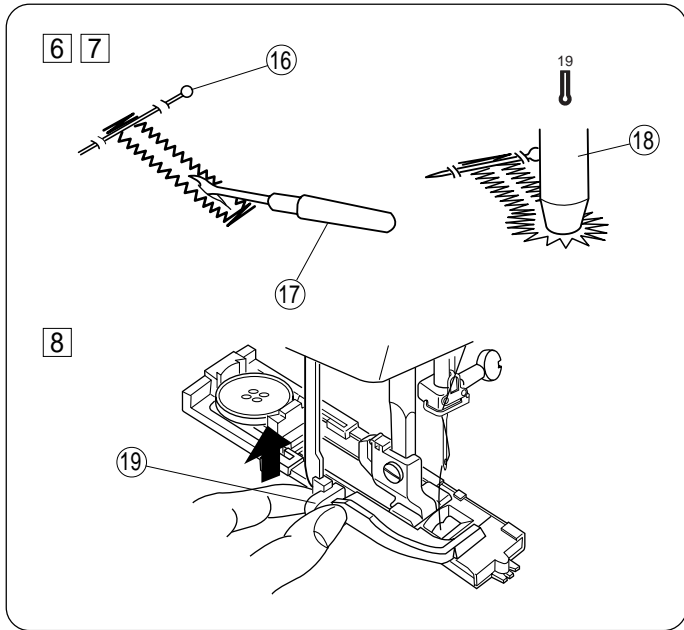

- 6 Remove the fabric and place a pin just before the bartack at each end to prevent cutting bartacks.
- 7 Cut the opening with the seam ripper. Use an awl to open the keyhole buttonhole.
 - 16 Pin
 - 17 Seam ripper
 - 18 Awl
- 8 After the buttonhole sewing is finished, push the buttonhole lever upward as far as it will go.
 - 19 Buttonhole lever

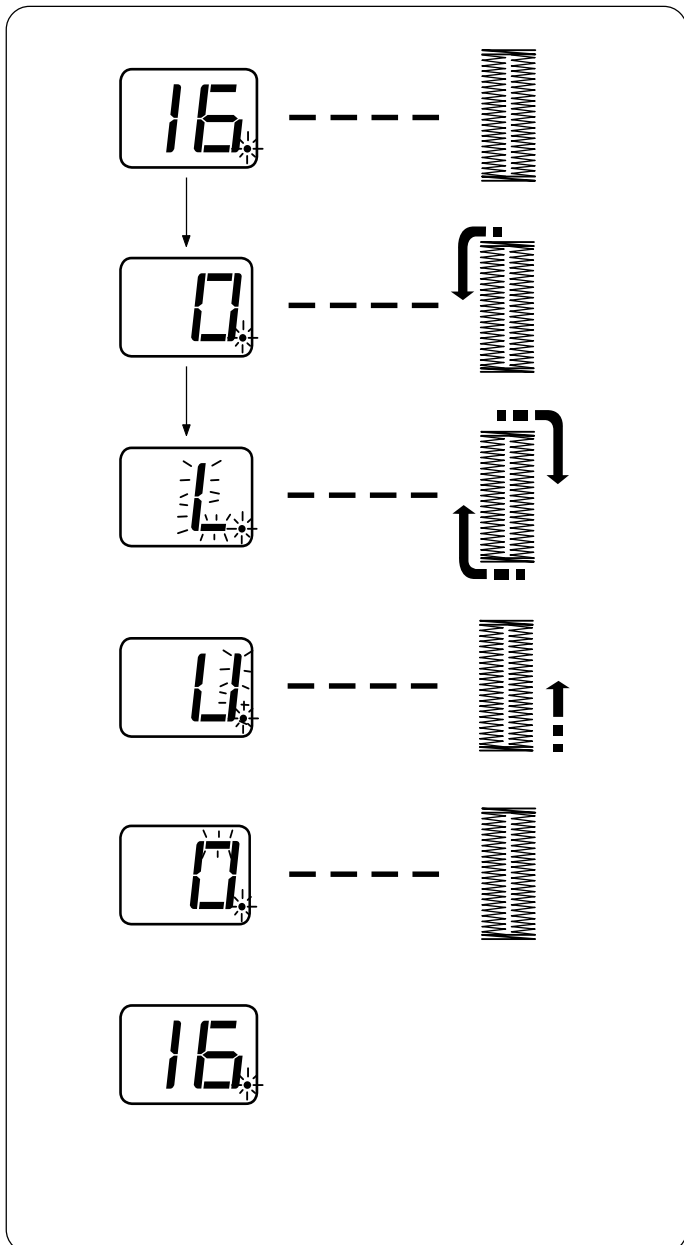

Double layer buttonhole

To make a solid and sturdy buttonhole, sew another layer of buttonhole over the previous one.

After the buttonhole is finished, simply depress the foot control again.

Do not raise the foot or reselect the pattern.

The machine will sew another buttonhole in the following order and stop automatically:

Straight stitching in reverse to go back to the starting point.

Front bartack and left row.

Right row.

Back bartack and locking stitches at the end.

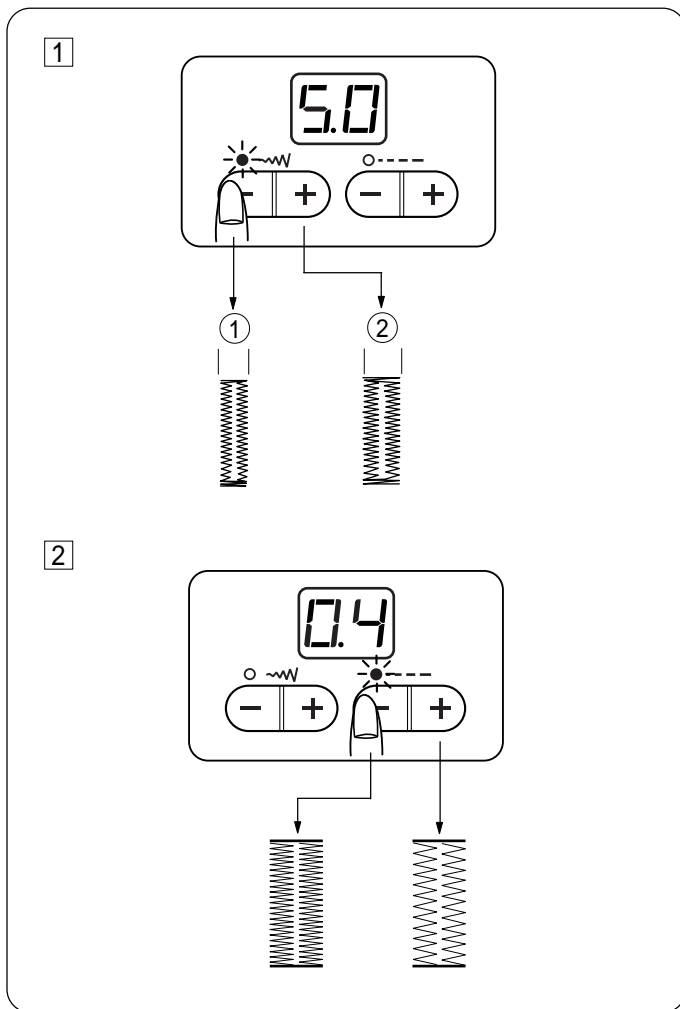

1 Adjusting the buttonhole width and density

Adjusting the buttonhole width.

Press the plus (+) key to increase buttonhole width.

Press the minus (-) key to decrease buttonhole width.

The LED display shows " 5.0 " (default setting) when the plus or minus key is pressed. The buttonhole width can be varied from 2.5 to 7.0.

- ① Narrow buttonhole (2.5mm wide)
- ② Wide buttonhole (7.0mm wide)

2 Adjusting the buttonhole stitch density

Press the plus (+) key for coarser stitch.

Press the minus (-) key for denser stitch.

The LED display shows " 0.4 " (default setting) when the plus or minus key is pressed. The stitch density can be varied from 0.2 to 0.8

The LED display does not show the sewing step when the adjusting mode is selected.

After the buttonhole sewing is finished, LED will show "0".

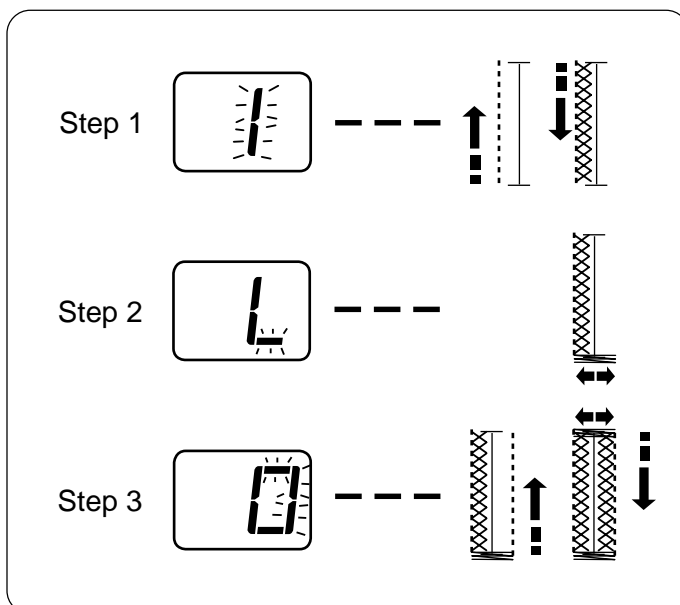

#20 Knit buttonhole

Depress the foot control and the machine will start sewing and stop automatically after buttonhole is completed.

Step 1: Sew up to the end with a straight stitch then sew down the left row.

Step 2: Sew the front bartack.

Step 3: Sew up to the end with a straight stitch then sew the back bartack. Sew down the right row and stop automatically.

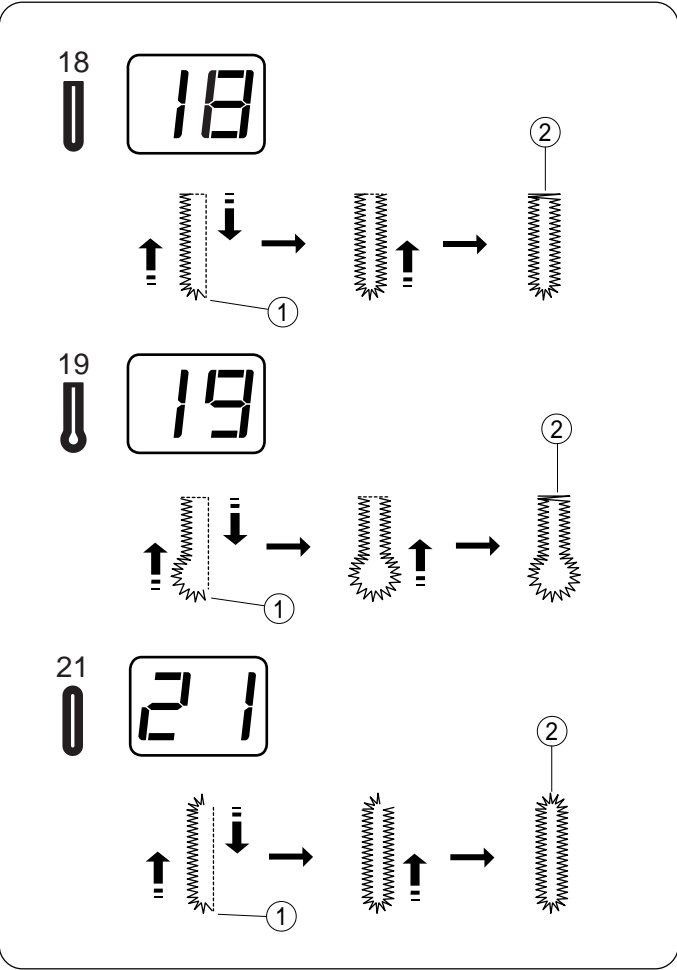

Round end/Keyhole buttonhole

Machine setting

- ① Pattern #18, #19 or #21
- ② LED display
- ③ Foot R: Automatic buttonhole foot

The sewing sequence is the same as sensor buttonhole. Refer to pages 26, 27, 28 for sewing instruction.

- ① Starting point
- ② End point

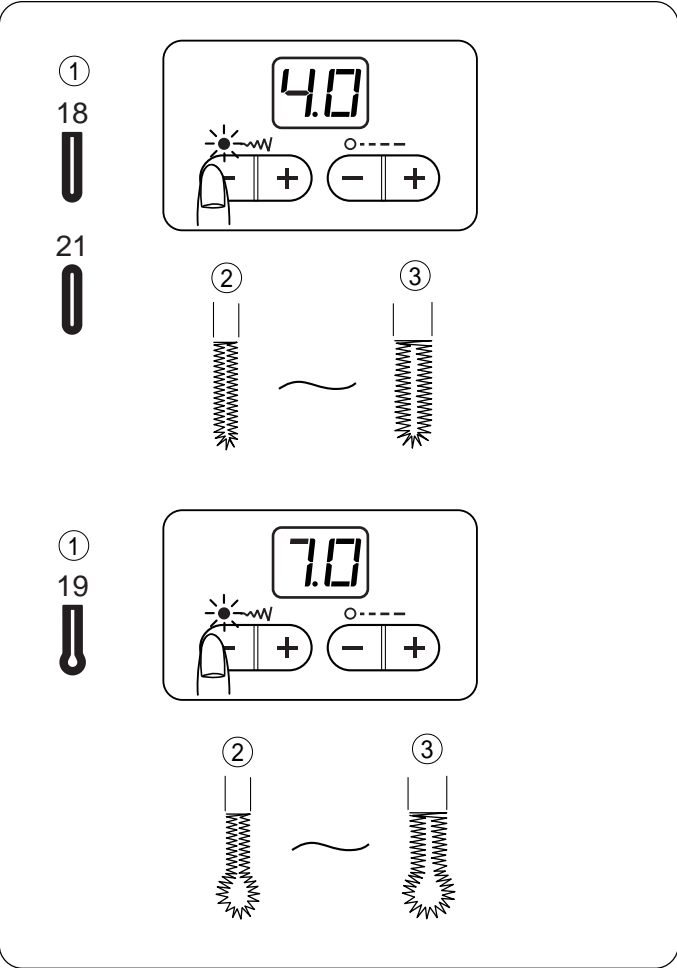

Adjusting the buttonhole width

Press the plus (+) key to increase buttonhole width.
 Press the minus (-) key to decrease buttonhole width.
 The width of round end buttonhole can be varied from 2.5 to 5.5.

- ② Narrow buttonhole (2.5mm wide)
- ③ Wide buttonhole (5.5mm wide)

The width of keyhole buttonhole can be varied from 5.0 to 7.0.

- ② Narrow buttonhole (5.0mm wide)
- ③ Wide buttonhole (7.0mm wide)

Refer to page 29 for stitch density adjustment.

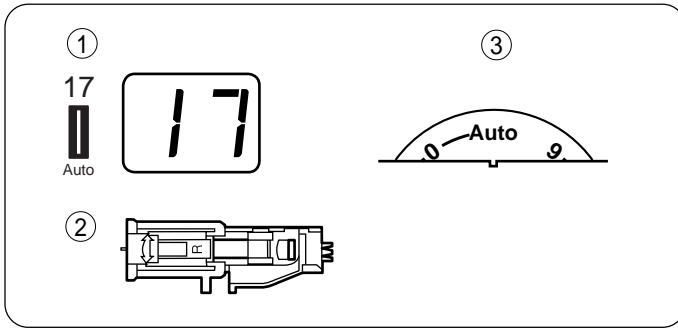

#17 Square buttonhole (Auto buttonhole)

Machine setting

- | | |
|------------------|------------------------------|
| ① Pattern | #17 |
| ② Foot | R: Automatic buttonhole foot |
| ③ Thread tension | Auto |

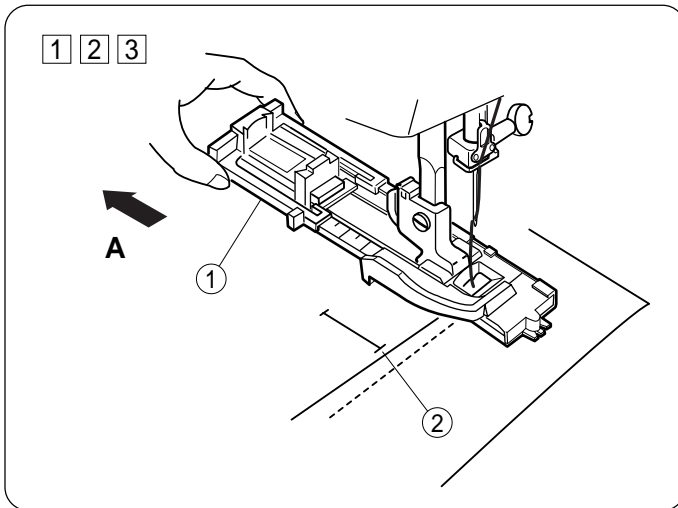

- 1 Mark the buttonhole position on the fabric. Pull the button holder all the way out.
- 2 Draw the needle thread to the left through the hole on the foot.
- 3 Place the fabric under the foot and lower the needle at the starting point by turning the handwheel. Lower the foot.

- ① Button holder
- ② Starting point

NOTE: You do not need to pull down the buttonhole lever.

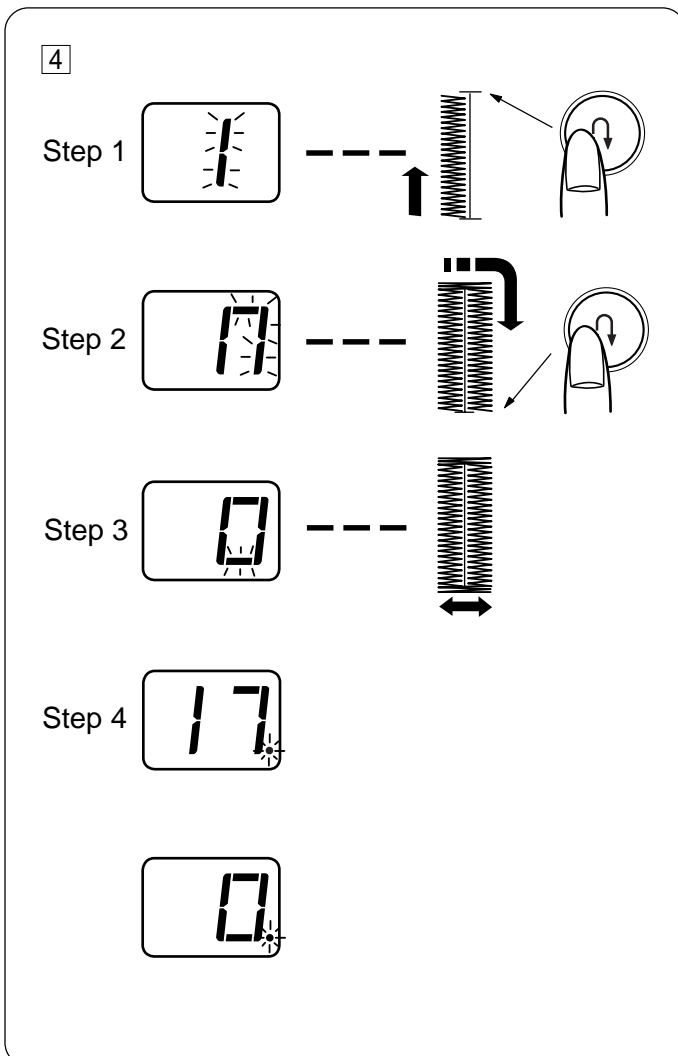

- 4 Depress the foot control and follow the steps below.

Step 1: Sew up the left row to the desired buttonhole length and stop the machine. Press the reverse stitch button.

Step 2: Depress the foot control again. The machine will automatically tack and sew down the right row. Stop the machine when you return to the starting point. Press the reverse stitch button.

Step 3: Depress the foot control again. The machine will sew the front bartack and stop automatically.

Step 4: After the buttonhole is completed, a blinking dot will appear on the LED display. Raise the presser foot.

NOTE: The blinking dot indicates that the buttonhole length has been memorized. If you wish to alter the stitch density, you need to re-select the auto buttonhole and repeat the above steps with a new stitch setting.

To sew buttonholes in the same size, simply depress the foot control. Keep the foot control depressed and the machine will sew the same sized buttonhole and stop automatically. You do not need to press the reverse stitch button.

The LED display shows "0" while sewing.

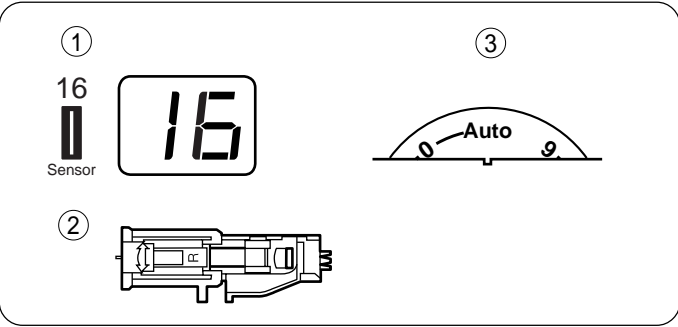

Corded Buttonholes

Machine setting

- ① Pattern #16
- ② Foot R: Automatic buttonhole foot
- ③ Thread tension Auto

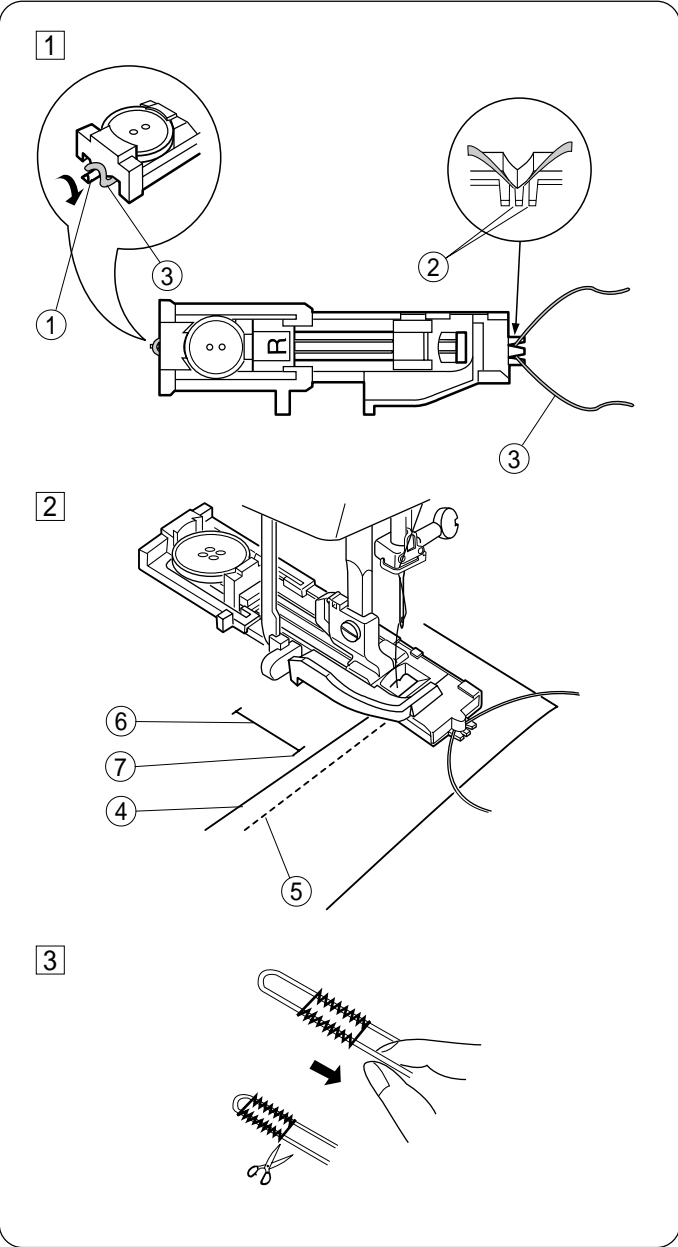

① With the buttonhole foot raised, hook the filler cord on the cord spur on the back of the buttonhole foot. Bring the ends toward you under the foot, and hook the filler cord into the forks on the front of the foot to hold them tight.

- ① Spur
- ② Forks
- ③ Cord

② Lower the needle into the garment where the buttonhole will start by turning the handwheel and lower the foot. Depress the foot control and sew the buttonhole over the cord.

NOTE: The sewing sequence is the same as the automatic buttonhole.

- ④ Needle thread
- ⑤ Bobbin thread
- ⑥ Buttonhole mark
- ⑦ Starting point

③ Remove the fabric and pull the left end of the cord to tighten it. Cut the excess cord.

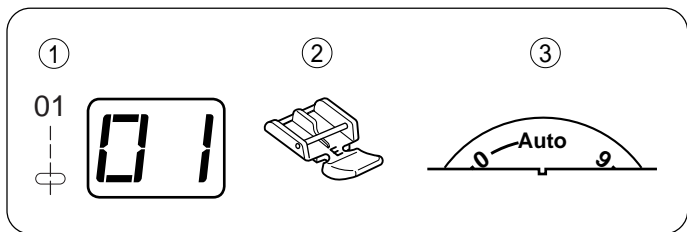

Zipper Application

Machine setting

- | | |
|------------------|----------------|
| ① Pattern | #01 |
| ② Foot | E: Zipper foot |
| ③ Thread tension | Auto |

To attach the zipper foot:

- (1) Attach the zipper foot with the pin on the right, when sewing on the left side of the zipper.
- (2) Attach the zipper foot with the pin on the left, when sewing on the right side of the zipper.

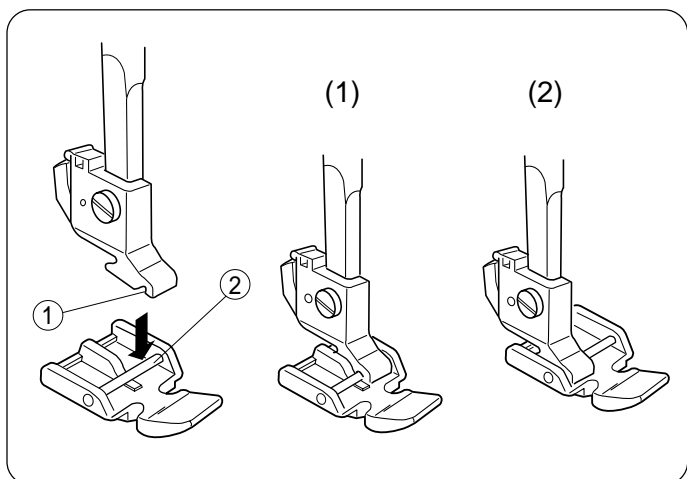

- ① Groove
- ② Pin

Fabric preparation:

- ① Add 1 cm (3/8") to the zipper size. This is the overall opening size.

- ③ Right side of the fabric
- ④ 1 cm (3/8")
- ⑤ Opening size
- ⑥ Zipper size
- ⑦ Slider
- ⑧ Zipper teeth
- ⑨ Zipper tape
- ⑩ Wrong side of the fabric
- ⑪ End of the opening

- ② Place the right sides of the fabric together and sew up to the end of the zipper opening, with a 2 cm (13/16") seam allowance. Reverse the stitch to fasten the seam. Baste along the zipper opening with the stitch length 4.0

- ⑫ 2 cm (13/16")
- ⑬ Zipper opening (Basting)
- ⑭ Reverse stitches
- ⑮ End of the opening
- ⑯ Seam

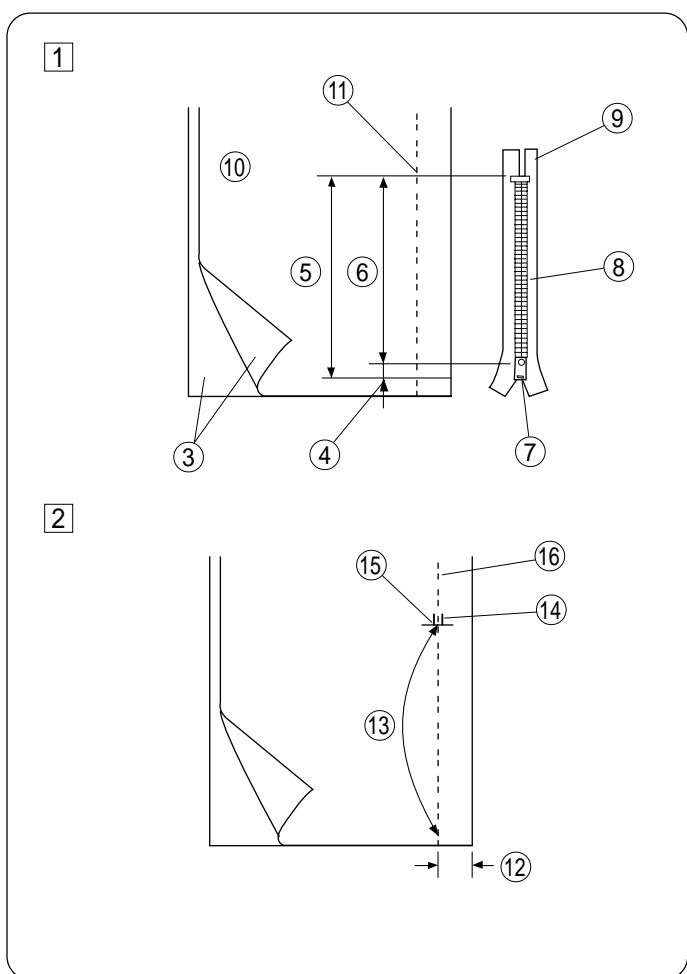

NOTE: Loosen the thread tension to one (1) for the basting stitch.

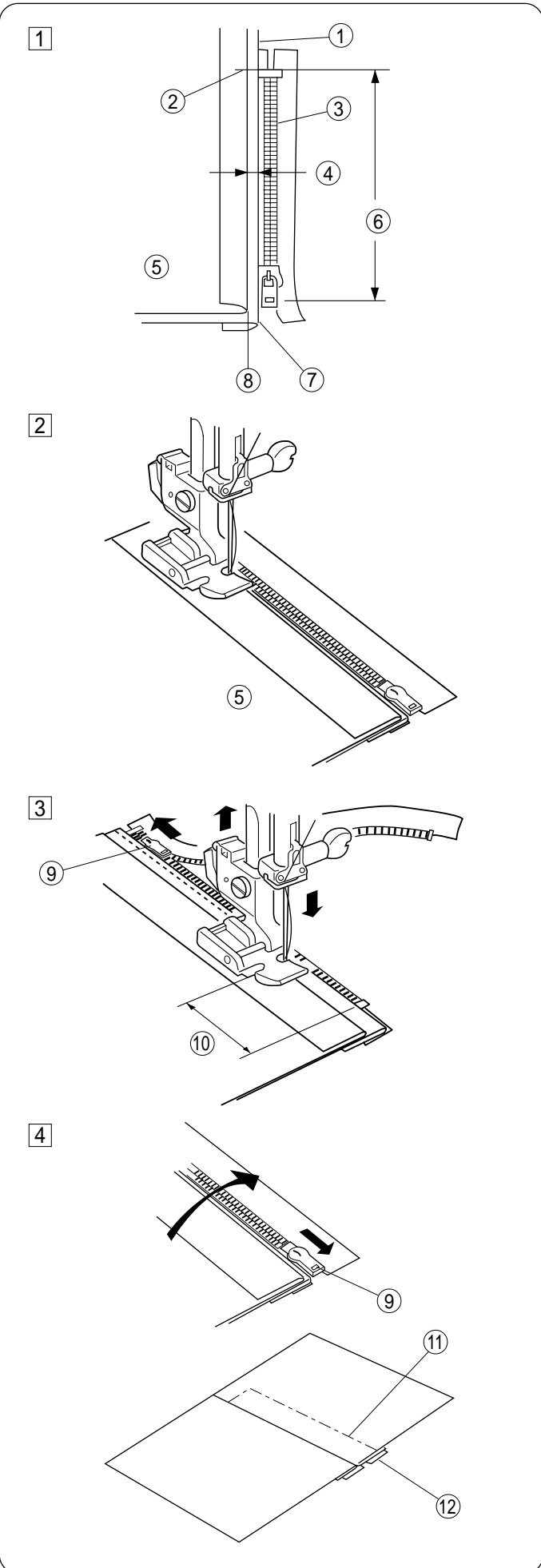

To sew:

- 1 Fold up the upper seam allowance. Fold back the bottom seam allowance to form a 0.3 cm (1/8") fold. Place the zipper teeth next to the fold and pin it in place.
 - ① Bottom fabric
 - ② End of the zipper opening
 - ③ Zipper teeth
 - ④ 0.3 cm (1/8")
 - ⑤ Wrong side of the upper fabric
 - ⑥ Opening size
 - ⑦ Fold
 - ⑧ Basting

- 2 Attach the foot with the pin on the right. Sew through all the layers from the end of the zipper opening, guiding the zipper teeth along the edge of the foot.

- 3 Stop the machine 5 cm (2") before the foot reaches the slider on the zipper tape. Lower the needle into the fabric, and raise the foot. Open the zipper, then lower the foot and stitch the remainder of the seam.
 - ⑨ Slider
 - ⑩ 5 cm (2")

- 4 Close the zipper and open the upper fabric flat over the zipper. Baste the upper fabric and zipper tape together.
 - ⑪ Basting stitch
 - ⑫ Zipper tape

5

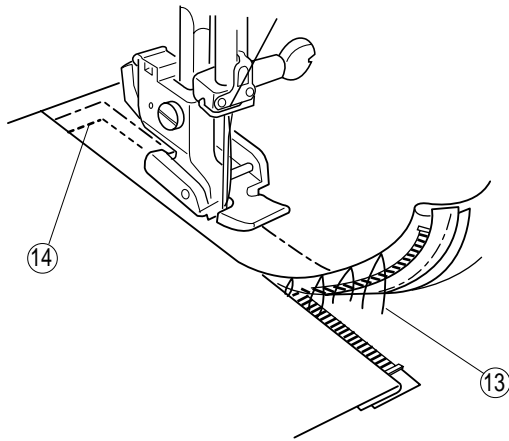

- 5 Detach the foot and attach it with the pin on the left. Backstitch across the end of opening to 1 cm (3/8"). Turn the fabric 90 degrees and stitch through the garment and zipper tape. Stop the machine 5 cm (2") before the foot reaches the slider on the zipper tape. Lower the needle into the fabric, and raise the foot. Unseam the basting stitches.
- 13 Basting stitches
 - 14 Backstitching

6

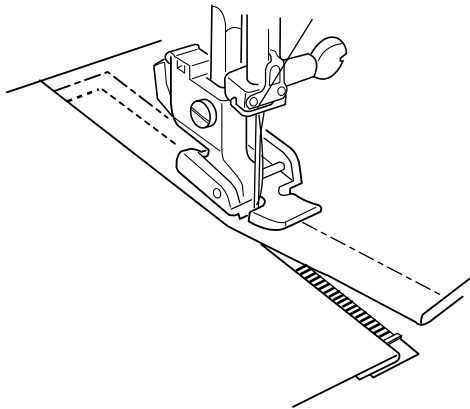

- 6 Open the zipper, then lower the foot and stitch the remainder of the seam. After finish sewing, remove the basting stitches on the upper fabric.

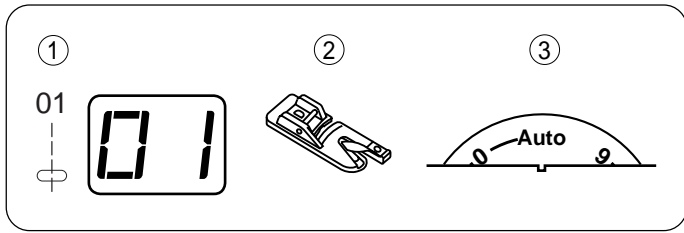

Rolled Hem

Machine setting

- | | |
|------------------|--------------------|
| ① Pattern | #01 |
| ② Foot | D: Rolled hem foot |
| ③ Thread tension | Auto |

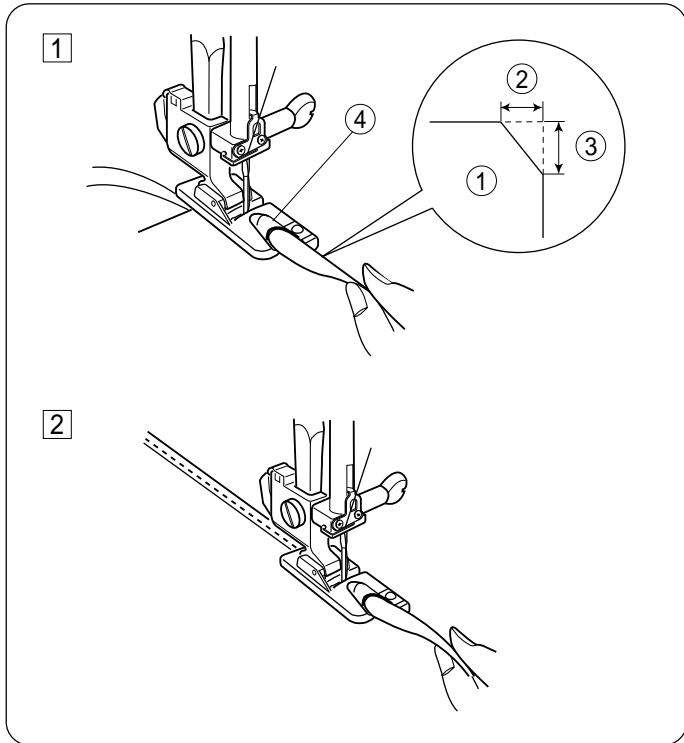

- ① Trim off the corner of the fabric 0.5 cm (3/16") by 0.8 cm (5/16") to avoid a bulkiness of the hem at the corner.

Fold the fabric edge twice 0.3 cm (1/8") wide and 6 cm (2 3/8") long.

- ① Wrong side of the fabric
- ② 0.5 cm
- ③ 0.8 cm
- ④ Curl of the foot

- ② Place the fabric aligning the hem edge with the guide on the foot. Lower the foot and sew several stitches while pulling both threads to the back.

Stop the machine with the needle in the fabric and raise the presser foot. Insert the folded portion of the fabric into the curl of the foot.

Lower the foot and sew while lifting up the fabric edge to keep it feeding smoothly and evenly.

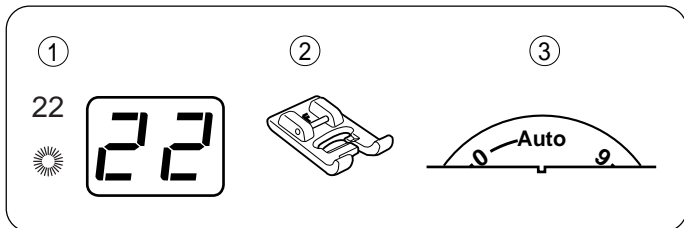

Eyelet

Machine setting

- | | |
|------------------|----------------------|
| ① Pattern | #22 |
| ② Foot | F: Satin stitch foot |
| ③ Thread tension | Auto |

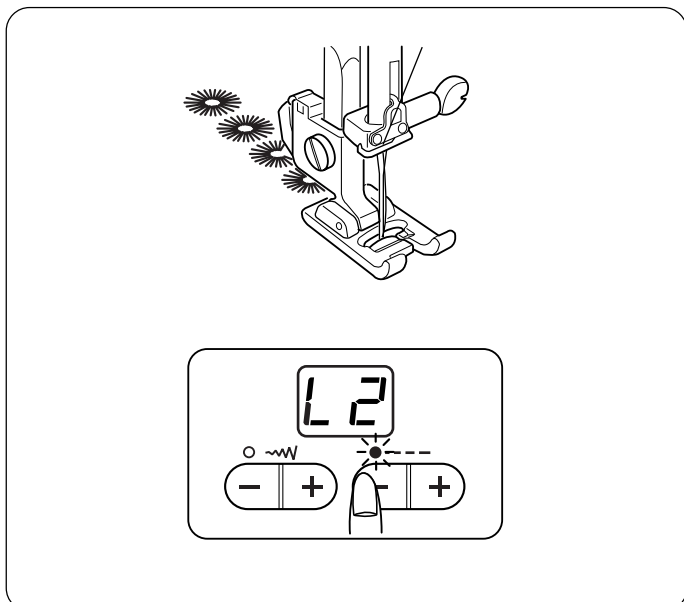

Depress the foot control and the machine will sew an eyelet and stop automatically.

Open the eyelet with a small awl or punch.

If the eyelet opens or overlaps when sewing on certain materials, correct it by pressing stitch length adjustment keys as follows:

Press the minus (-) key if the eyelet is open (The LED display shows "L1").

Press the plus (+) key if the eyelet overlaps (The LED display shows "L3").

NOTE: The default setting is "L2".

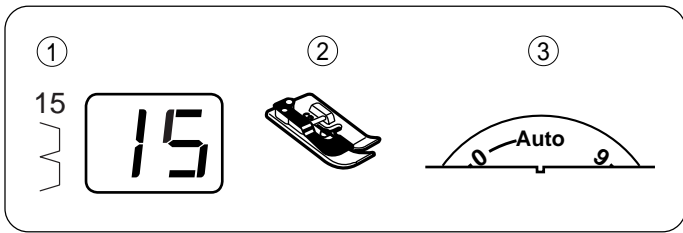

Blind Hem Stitch

Machine setting

- | | |
|------------------|-------------------|
| ① Pattern | #14, #15 |
| ② Foot | G: Blind hem foot |
| ③ Thread tension | Auto |

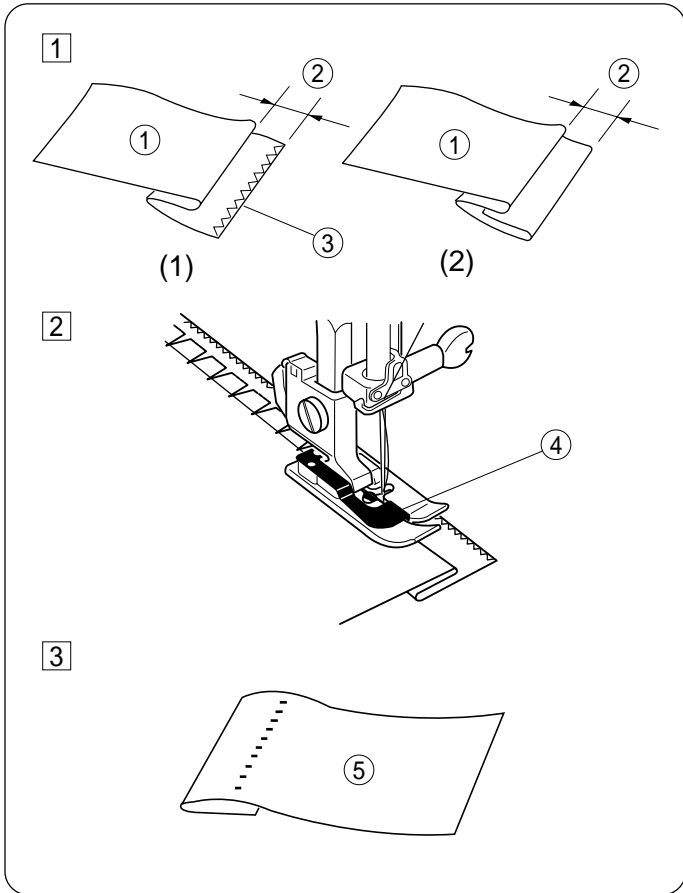

- ① Fold a hem with the wrong side up forming a 0.4-0.7 cm (3/16-5/16") allowance.

- ① Wrong side of the fabric
- ② 0.4-0.7 cm (3/16-5/16")
- ③ Overcasting

- (1) On heavy weight fabrics that ravel, the raw edge should be overcast first.
(2) Fold the hem under the fabric as illustrated for fine or medium fabrics.

- ② Place the fabric so that the folded edge is next to the guide on the foot. Lower the presser foot. Adjust the needle drop position if necessary. Sew guiding the folded edge along the guide on the foot.

- ④ Guide

- ③ Open the fabric after sewing is finished.

- ⑤ Right side of the fabric

NOTE: If the needle pierces too far left, the stitches will show on the right side of fabric.

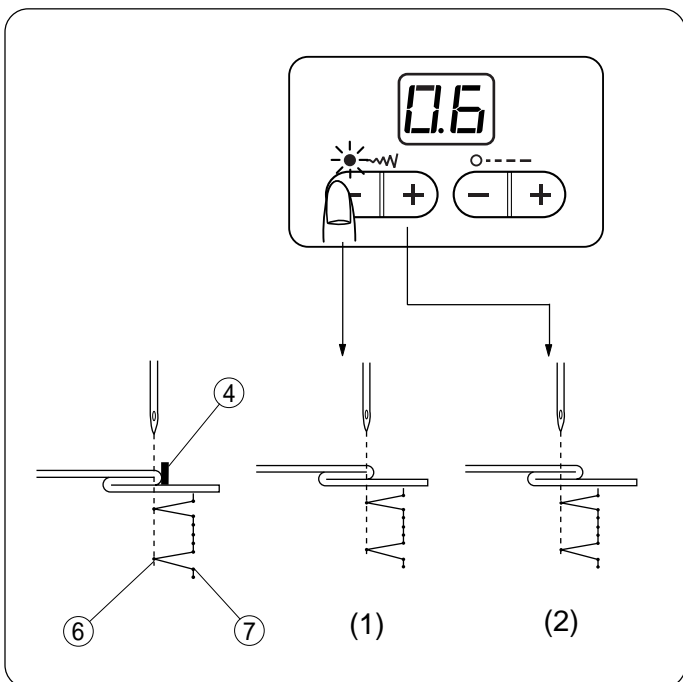

Adjusting the needle drop position

The needle drop position can be adjusted by pressing the stitch width adjustment keys.

- (1) Press the plus (+) key to move the needle drop position to the left.
- (2) Press the minus (-) key to move the needle drop position to the right.

The LED display shows "0.6" that indicates a distance between the guide and left needle drop position in millimeter.

NOTE: The needle drop position will move to the left or right, but the stitch width is remained the same.

- ④ Guide
- ⑥ Left needle drop position
- ⑦ Right needle drop position

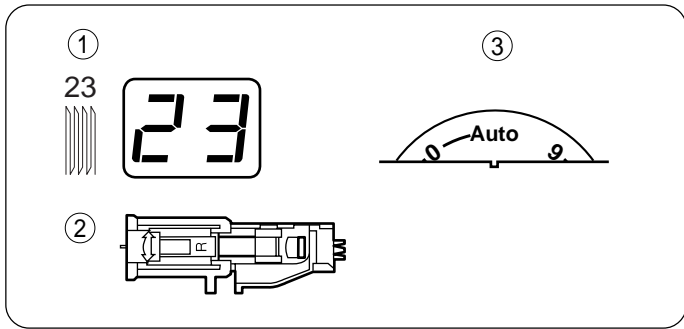

Darning

Machine setting

- | | |
|------------------|------------------------------|
| ① Pattern | #23 |
| ② Foot | R: Automatic buttonhole foot |
| ③ Thread tension | Auto |

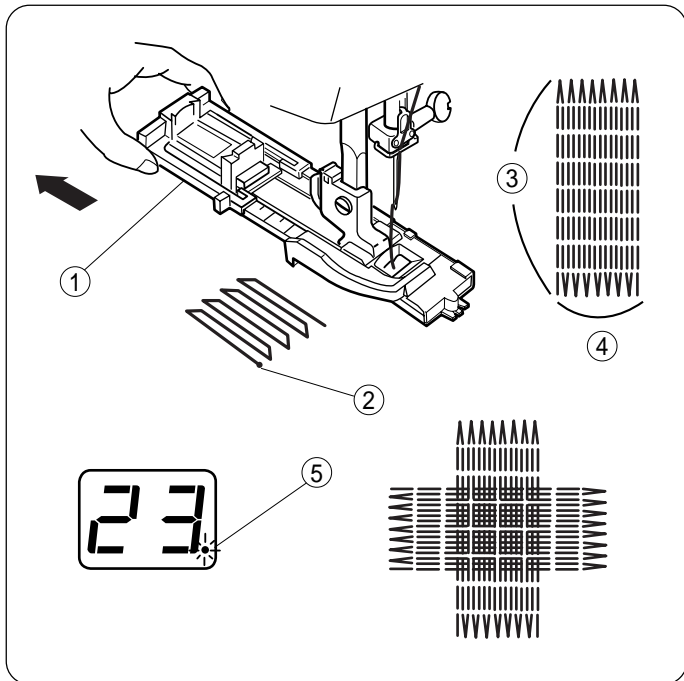

1. Pull the button holder all the way out.
2. Draw the needle thread to the left through the hole on the foot.
3. Lower the needle into the fabric where start to sew. Lower the foot and depress the foot control.
4. The machine will darn and stop automatically. The LED display will show a blinking dot when the darning is finished.

NOTE: The maximum length and width of the darning are 2.5 cm and 0.7cm respectively.
Sew another layer of darning over the previous one, at the right angle.

- ① Button holder
- ② Starting point
- ③ Maximum length (2.5 cm)
- ④ Maximum width (0.7 cm)
- ⑤ Blinking dot

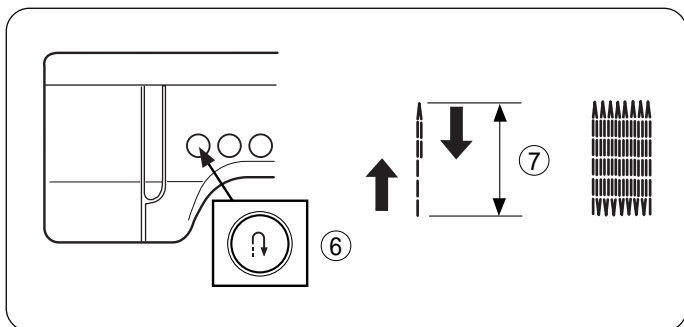

To sew a shorter darning

Sew the first row to the required length and press the reverse stitch button. Continue to sew the remaining stitches until the machine stops automatically.

- ⑥ Reverse stitch button
- ⑦ Required length

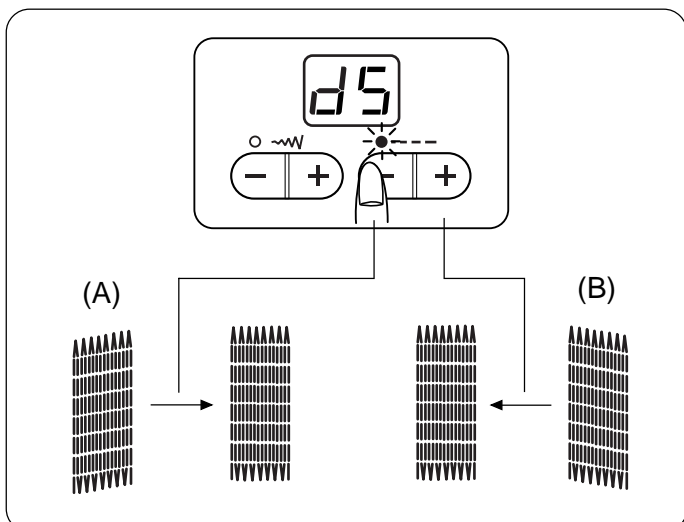

Adjusting the evenness of the darning

If the darning is not even, correct it by pressing the stitch length adjusting keys.

The LED display shows d5, which indicates the neutral setting.

- (A) If the left corner is lower than the right side, press the minus (-) key to correct it.
- (B) If the right corner is lower than the left side, press the plus (+) key to correct it.

NOTE: Allowable adjustment range is d1-d9.

SEWING APPLICATION AND DECORATIVE STITCHES

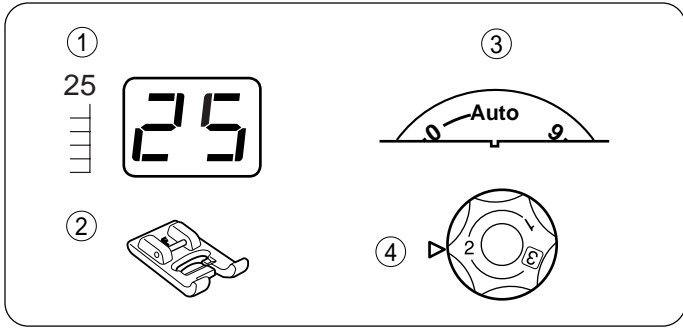

Appliqué

Machine setting

- ① Pattern #25
- ② Foot F: Satin stitch foot
- ③ Thread tension Auto
- ④ Foot pressure 2

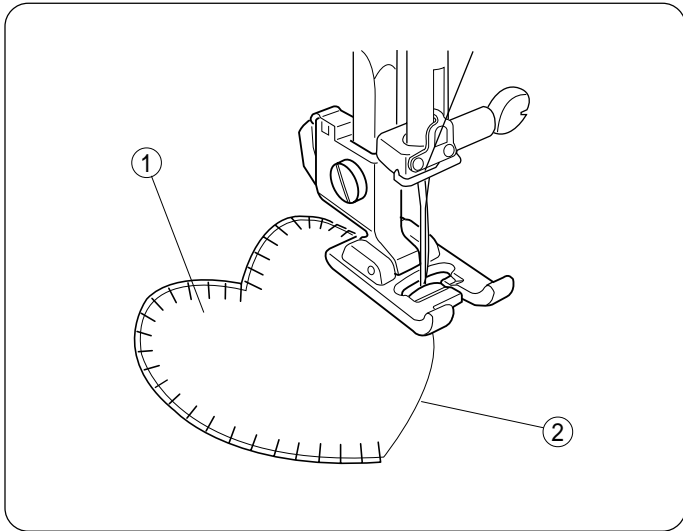

The patterns #05 and #26 can also be used.

Baste or glue appliqué pieces on the fabric.

Stitch around the appliqué making sure the needle falls along the outer edge of the appliqué.

When turning corners, lower the needle down into the outer edge of the appliqué, and raise the presser foot to pivot the fabric.

- ① Appliqué
- ② Outer edge

NOTE: Return the foot pressure dial to “ 3 ” after appliqué sewing is finished.

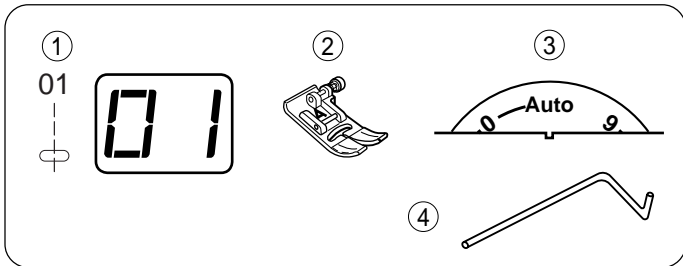

Quilting

Machine setting

- ① Pattern #01
- ② Foot A: Zigzag foot
- ③ Thread tension Auto
- ④ L: Quilting bar

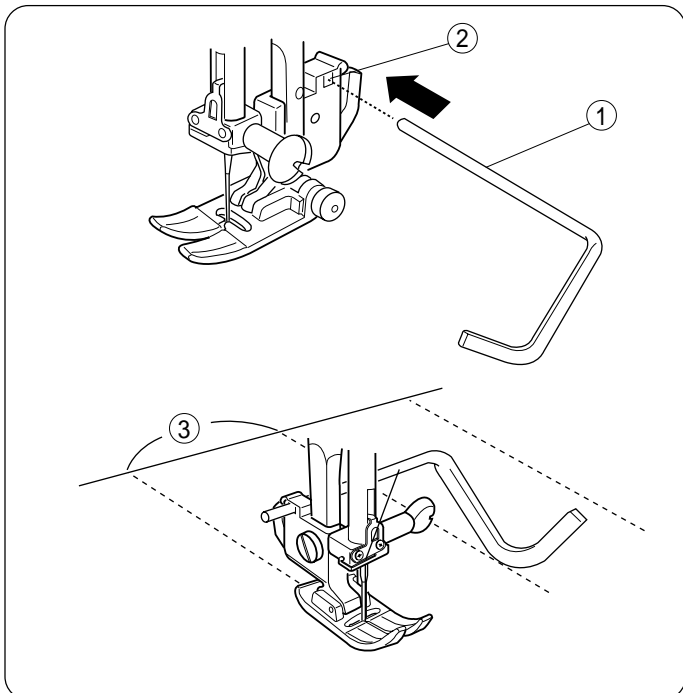

Insert the quilting bar into the opening on the back of the foot holder.

Shift the quilting bar to the desired position.

Sew tracing the previous seam with the quilting bar to keep constant seam spacing.

- ① Quilting bar
- ② Opening
- ③ Seam spacing

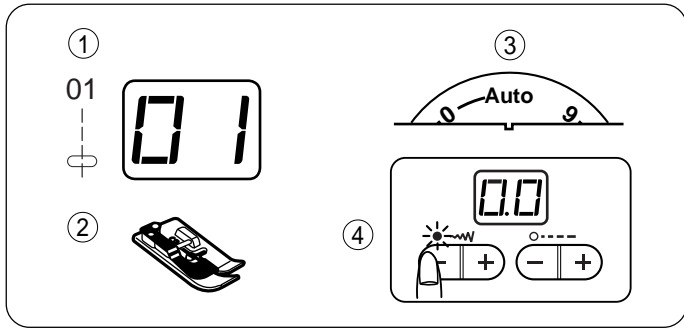

Pin Tucking

Machine setting

- | | |
|------------------------|-------------------|
| ① Pattern | #01 |
| ② Foot | G: Blind hem foot |
| ③ Thread tension | Auto |
| ④ Needle drop position | Left (0.0) |

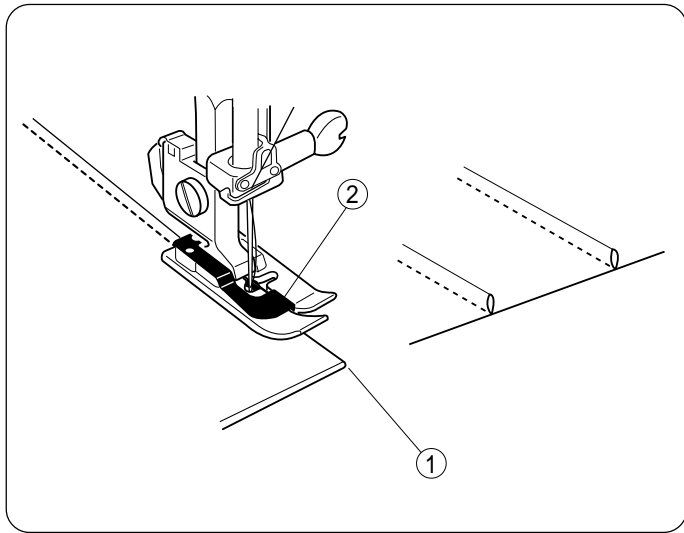

Fold the fabric with wrong side together.

Position the fabric so that the folded edge is next to the guide on the presser foot. Lower the foot and Sew guiding the folded edge along the guide.

Open the fabric and press the tucks to one side.

- ① Folded edge
- ② Guide

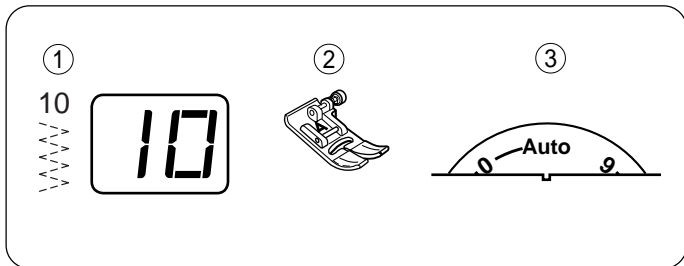

Patchwork

Machine setting

- | | |
|------------------|----------------|
| ① Pattern | #10 |
| ② Foot | A: Zigzag foot |
| ③ Thread tension | Auto |

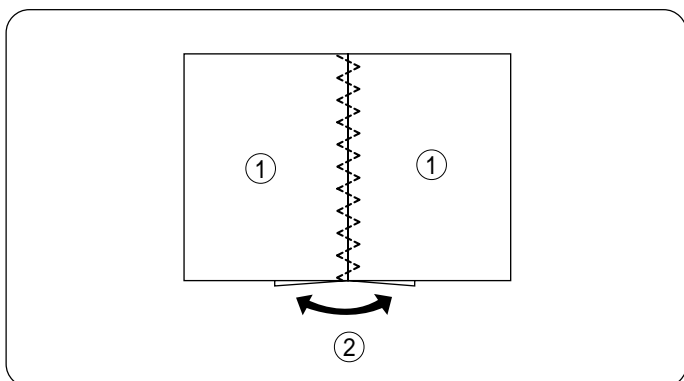

Seam two layers of the fabric with right side together.

Open the fabric flat and sew the pattern over the seam line on the right side of the fabric.

- ① Right side of the fabric
- ② Open the seam

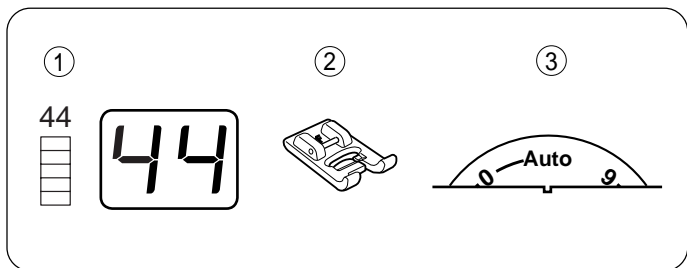

Fagoting

Machine setting

- | | |
|------------------|----------------------|
| ① Pattern | #44 |
| ② Foot | F: Satin stitch foot |
| ③ Thread tension | Auto |

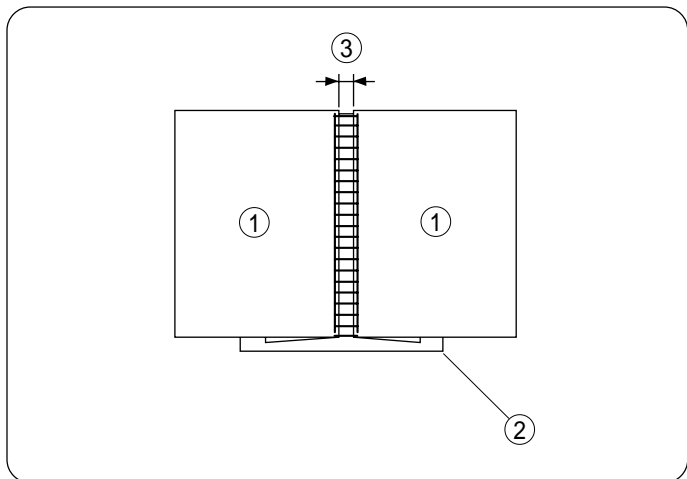

Fold under 1.5 cm (1/2") on each fabric edge and press. Pin the two edges to a piece of paper 0.3 cm (1/8") apart.

Sew guiding the fabric so the needle catches the folded edge on each side.

Peel off the paper from fabrics.

- ① Right side of the fabric
- ② Paper
- ③ 0.3 cm (1/8")

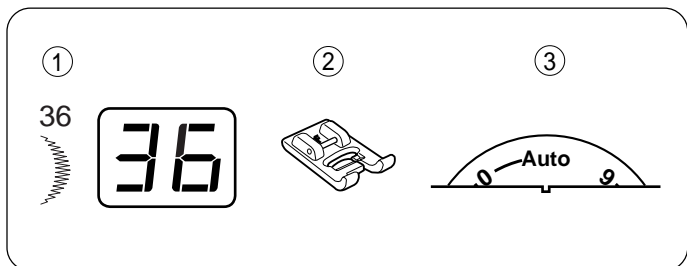

Scallop Stitch

Machine setting

- | | |
|------------------|----------------------|
| ① Pattern | #36 |
| ② Foot | F: Satin stitch foot |
| ③ Thread tension | Auto |

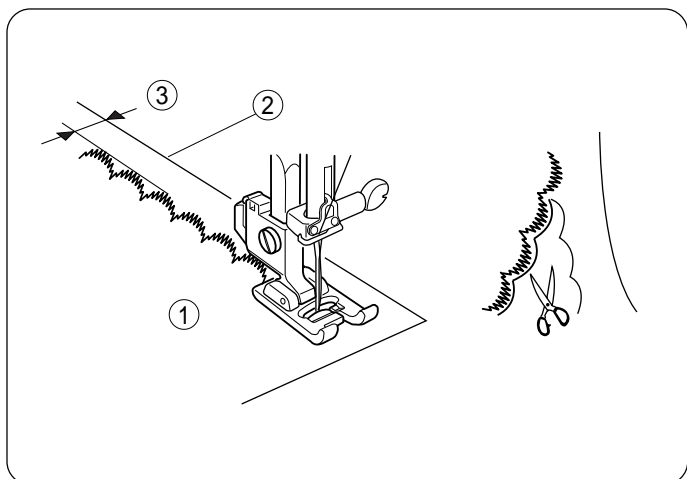

The pattern #28 can also be used.

Sew on the right side of fabric along the edge leaving a 1cm allowance.

After sewing, trim the allowance close to the stitching taking care not to cut the thread.

- ① Right side of the fabric
- ② Edge of the fabric
- ③ 1 cm (3/8")

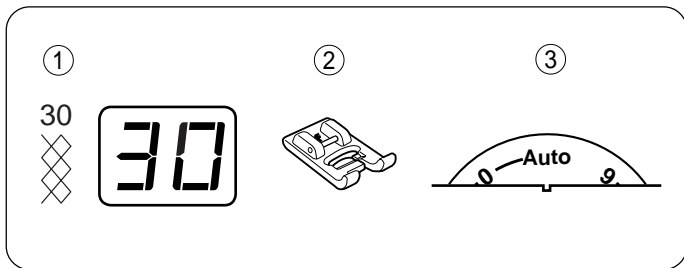

Smocking

Machine setting

- | | |
|------------------|----------------------|
| ① Pattern | #30 |
| ② Foot | F: Satin stitch foot |
| ③ Thread tension | Auto |

The patterns #51 to #55 can also be used.

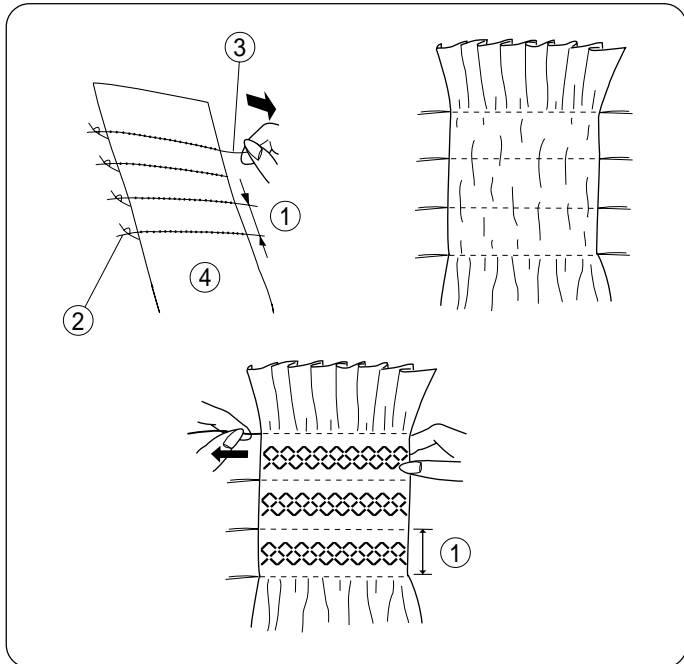

1. Set the thread tension dial at 1-3, and stitch length at 3-4, sew straight lines 1 cm (3/8") apart across the area to be smocked.

Knot the needle and bobbin threads along one edge. Pull the bobbin threads and distribute gathers evenly.

2. Sew lines of the decorative pattern between the straight seams. Pull out the gathering stitches.

- ① 1 cm (3/8")
- ② Knot both threads
- ③ Bobbin thread

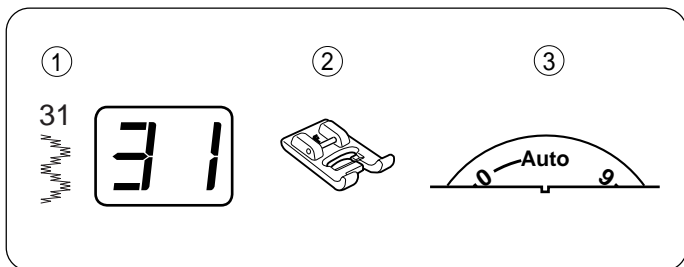

Decorative Satin Stitches

Machine setting

- | | |
|------------------|----------------------|
| ① Pattern | #31 |
| ② Foot | F: Satin stitch foot |
| ③ Thread tension | Auto |

The patterns #32 to #42 can also be used.

For fine and stretch fabrics, use an adhesive type stabilizer or a piece of paper on the wrong side of the fabric to prevent puckering.

NOTE: Press the auto lock button while sewing the last unit of the pattern so the machine will stop automatically after finishing the last unit.

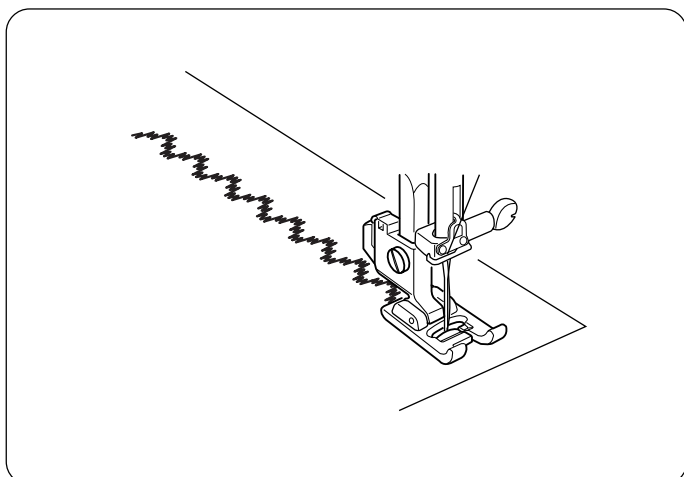

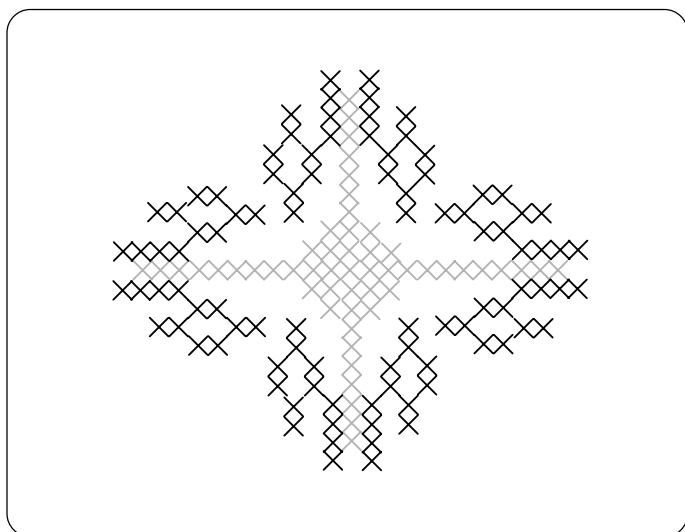
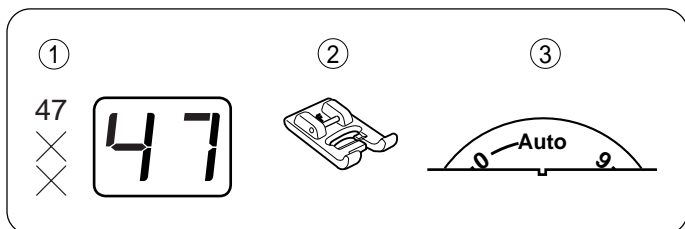
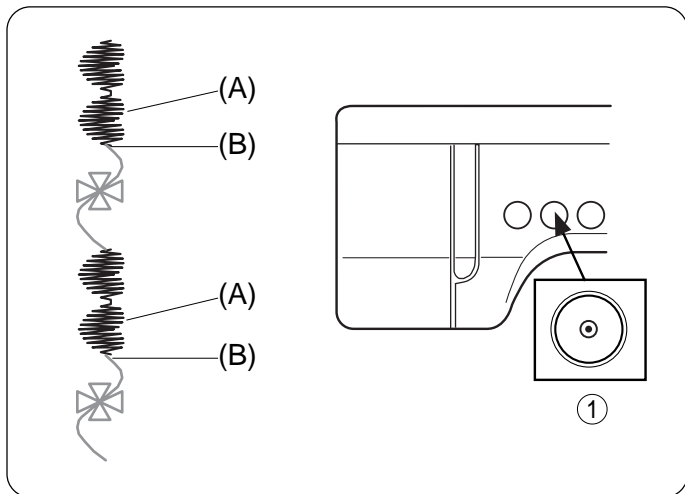
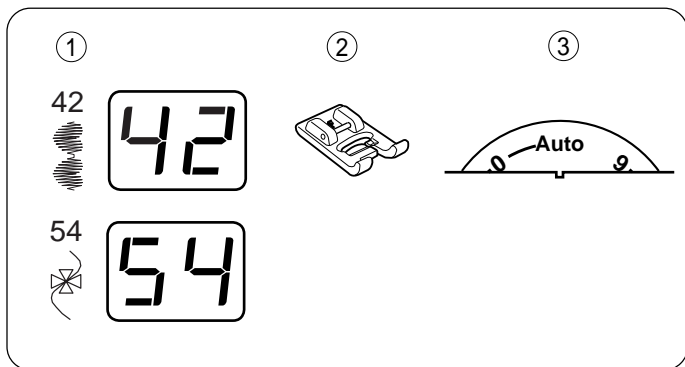

Pattern Combination

Machine setting

- | | |
|------------------|----------------------|
| ① Pattern | #42 and #54 |
| ② Foot | F: Satin stitch foot |
| ③ Thread tension | Auto |

You can sew a combination of decorative pattern with the aid of the auto lock button.

- ① Auto lock button

Example: To sew a combination of two units of the pattern #42 and one unit of #54.

1. Select the pattern #42 and sew. Press the auto lock button while sewing the second unit.
2. The machine will stop automatically when the second unit is completed.
3. Select the pattern #54 and press the auto lock button.
4. Depress the foot control, and the machine will sew one unit of the pattern and stop automatically. Repeat the above steps to sew a line of the pattern combination

Cross Stitch

Machine setting

- | | |
|------------------|----------------------|
| ① Pattern | #47 |
| ② Foot | F: Satin stitch foot |
| ③ Thread tension | Auto |

The patterns #48-50 can also be used.

You can make an embroidery design with this cross stitch pattern in a half time it would take by hand.

NOTES: The pattern size can be reduced by pressing minus (–) key for the stitch width adjustment. If you press the auto lock button before starting to sew, the machine will sew one unit of the pattern and stop automatically.

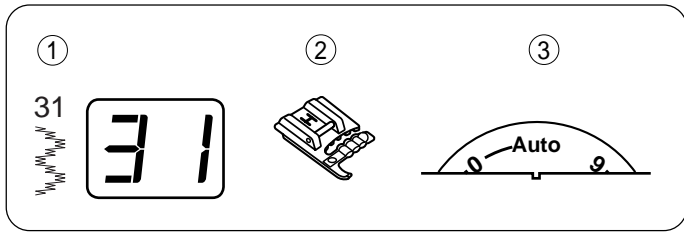

Cording

3-strand cording

Machine setting

- | | |
|------------------|-----------------|
| ① Pattern | #31 |
| ② Foot | H: Cording foot |
| ③ Thread tension | Auto |

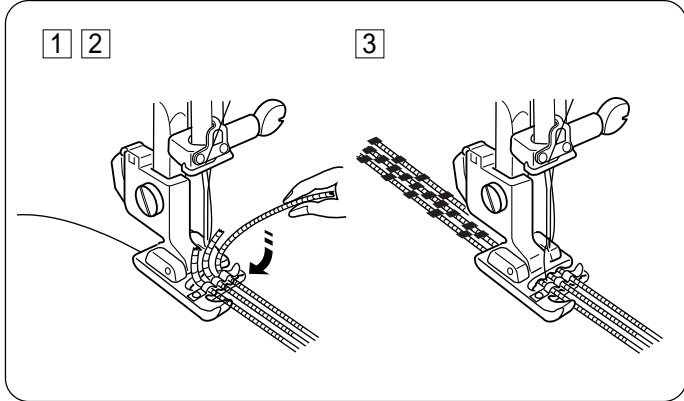

- ① Insert 3 strands of cord under the spring blade on the foot and draw them under the foot to the back.
- ② Hold the 3 strands parallel and stitch over the cords evenly.
- ③ Fine wool yarns and lace yarns can be used for cording.

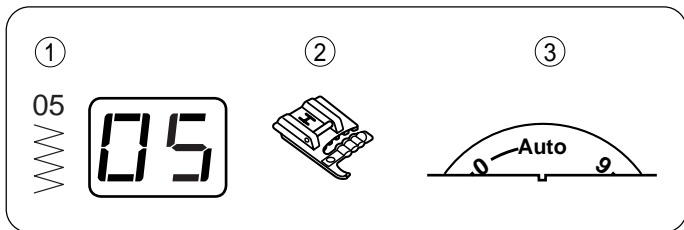

1-strand cording

Machine setting

- | | |
|------------------|-----------------|
| ① Pattern | #05 |
| ② Foot | H: Cording foot |
| ③ Thread tension | Auto |

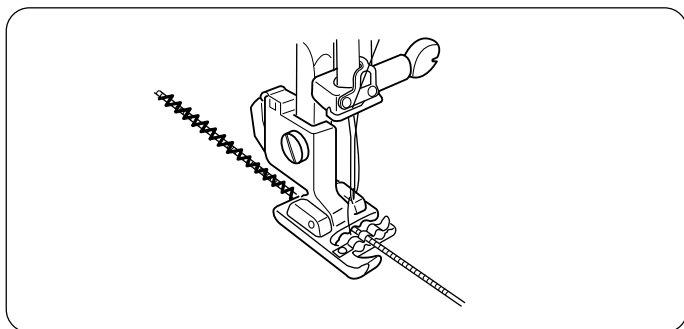

Insert a strand of cord under the center slot of spring blade on the foot and draw them under the foot to the back.

Reduce the stitch width according to thickness of the cord and sew.

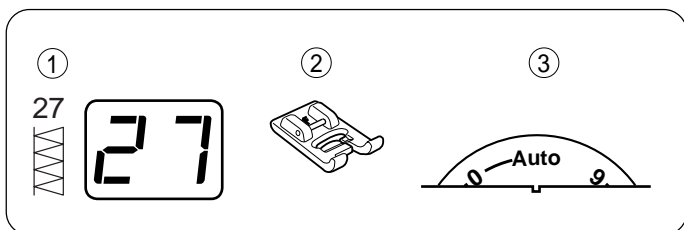

Elastic Stretch Stitch

Machine setting

- | | |
|------------------|----------------------|
| ① Pattern | #27 |
| ② Foot | F: Satin stitch foot |
| ③ Thread tension | Auto |

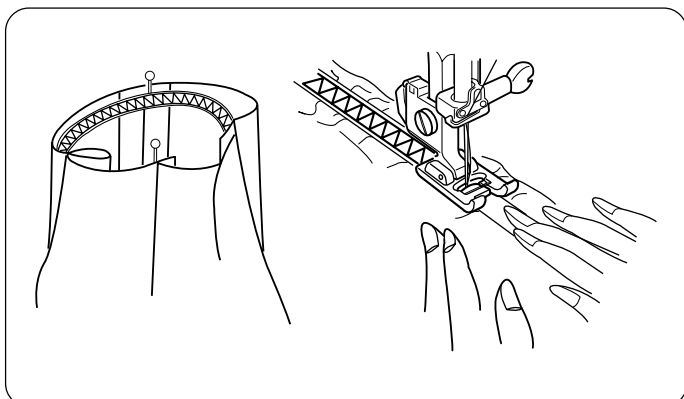

Mark the elastic into quarters and match these to the center front, center back and side seams.

Lower the foot on the elastic so that it is positioned in the center of the foot.

Sew over the elastic while pulling to stitch it evenly.

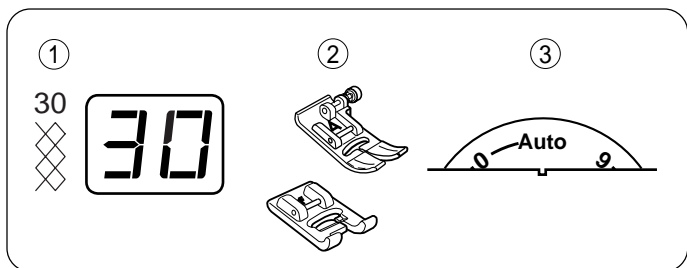

Decorative Stretch Stitches

Machine setting

- | | |
|------------------|--------------------------------------|
| ① Pattern | #06-09, #11-13,
#24-30 and #43-60 |
| ② Foot | A: Zigzag foot |
| ③ Thread tension | Auto |

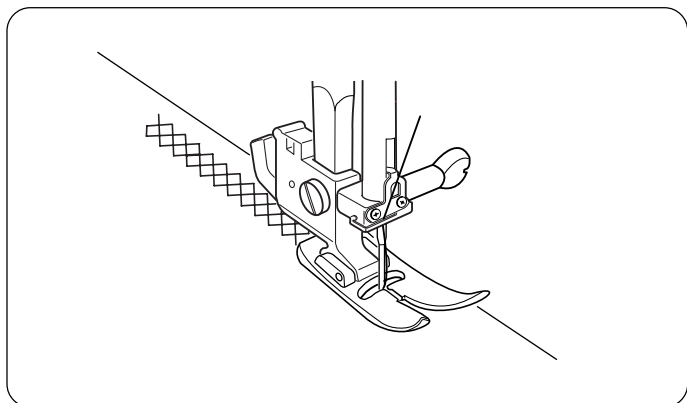

As the fabric moves back and forth in the stretch stitch sewing, guide the fabric carefully to keep the seams straight,

NOTE: If the patterns are uneven when sewing with a particular fabric, adjust them with the stretch stitch balancing dial.

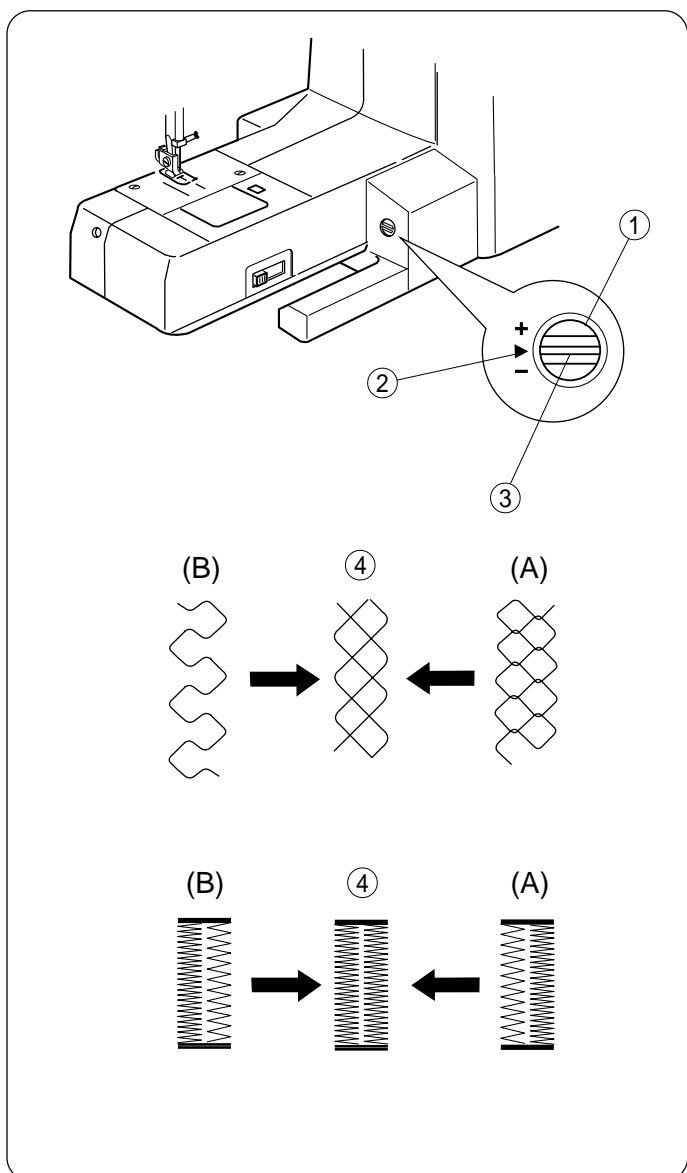

Adjusting Stretch Stitch Balance

The sewing results of the stretch stitch patterns may vary depending upon the sewing conditions, such as sewing speed, type of the fabric, number of layers etc.

Always make test sewing on a scrap piece of the fabric that you wish to use.

- (A) If the pattern is compressed, turn the stretch stitch balancing dial in the direction of “+”.
- (C) If the pattern is drawn out, turn the stretch stitch balancing dial in the direction of “-”.

NOTE: In normal sewing, set the dial to the neutral position, i.e. the groove on the dial is centered with the standard setting mark.

- ① Stretch stitch balancing dial
- ② Standard setting mark
- ③ Groove
- ④ Correct shape

This dial is also used to adjust the pitch balance of the auto buttonhole.

- (A) If the left row is coarser than right, turn the stretch stitch balancing dial in the direction of “+”.
- (B) If the right row is coarser than left, turn the stretch stitch balancing dial in the direction of “-”.

CARE OF YOUR MACHINE

Replacing the Light Bulb

WARNINGS: Turn OFF the power before replacing the light bulb.

The bulb could be HOT, wait until it has cooled down before touching it.

To remove:

Remove the cap and setscrew on the faceplate.

Remove the faceplate.

Pull out the bulb from the socket.

To Replace:

Insert the bulb into the opening of the socket.

Attach the faceplate.

Tighten the setscrew and attach the cap.

- ① Face plate
- ② Cap
- ③ Setscrew
- ④ Lamp Socket
- ⑤ Light bulb

NOTE: Replace the bulb with the same type rated 12V, 5W. Always refer the part number #000026002 when ordering a replacement bulb.

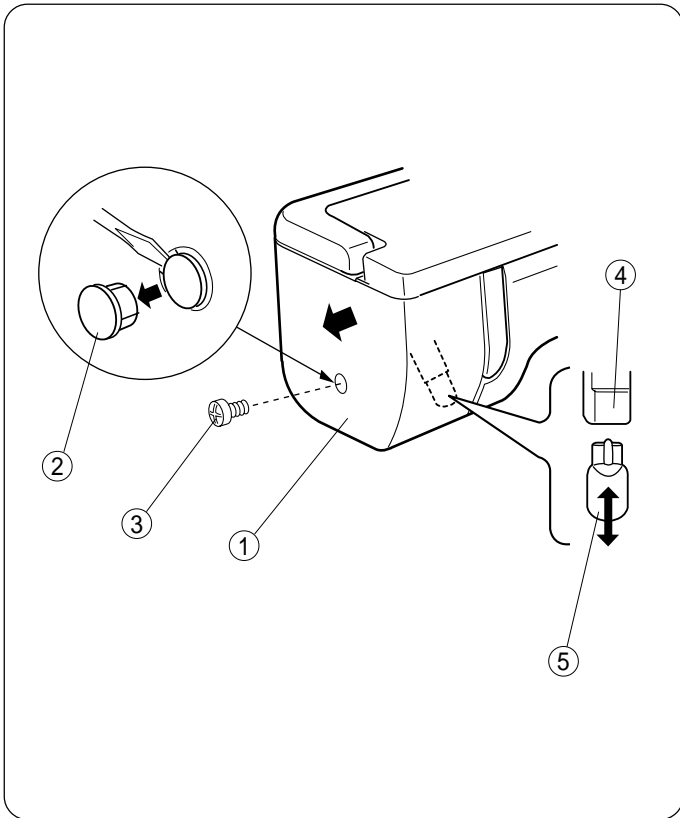

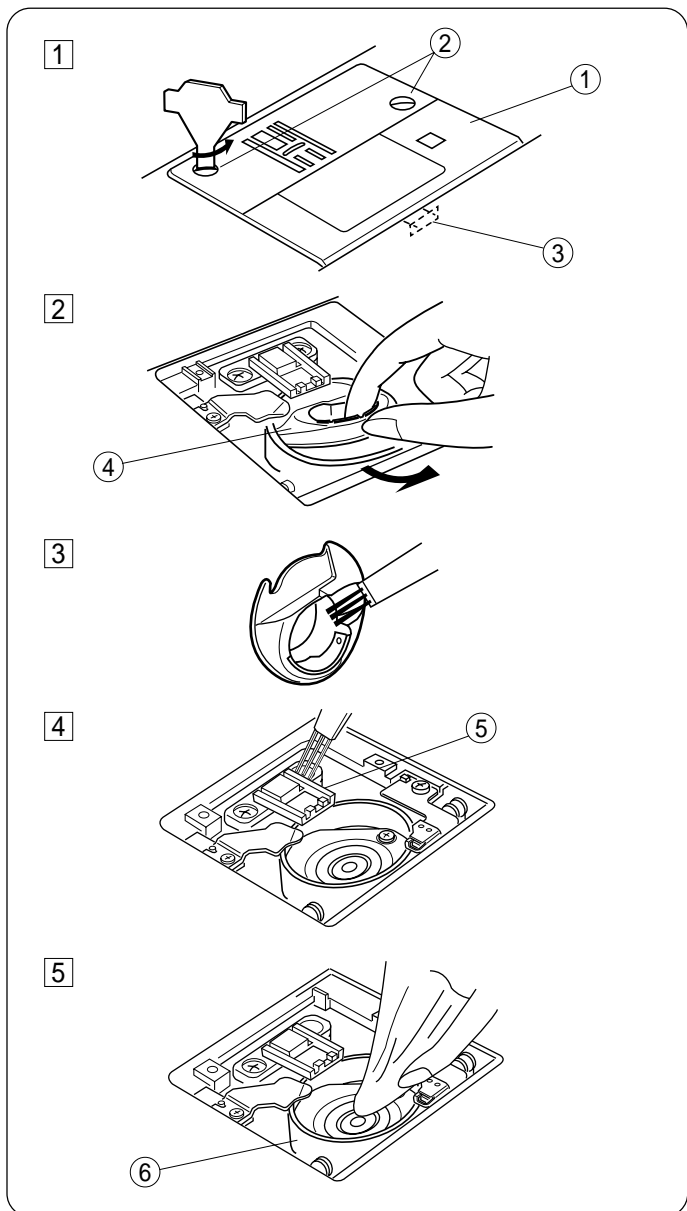

Cleaning Hook Race and Feed Dog

WARNING: Raise the presser foot and needle, and then unplug the machine.
DO NOT dismantle the machine other than as explained in this section.

- 1 Remove the needle and presser foot.
Remove the two setscrews and unhook the hook to remove the needle plate.
 - ① Needle plate
 - ② Setscrew
 - ③ Hook
- 2 Take out the bobbin and bobbin holder.
 - ④ Bobbin holder
- 3 Clean the bobbin holder with the lint brush and soft dry cloth.
- 4 Brush out dust and lint from the feed dog and clean the hook race with the lint brush.
 - ⑤ Feed dog
- 5 Wipe inside of the hook race with a dry cloth.
 - ⑥ Hook race

NOTE: You may use vacuum cleaner.

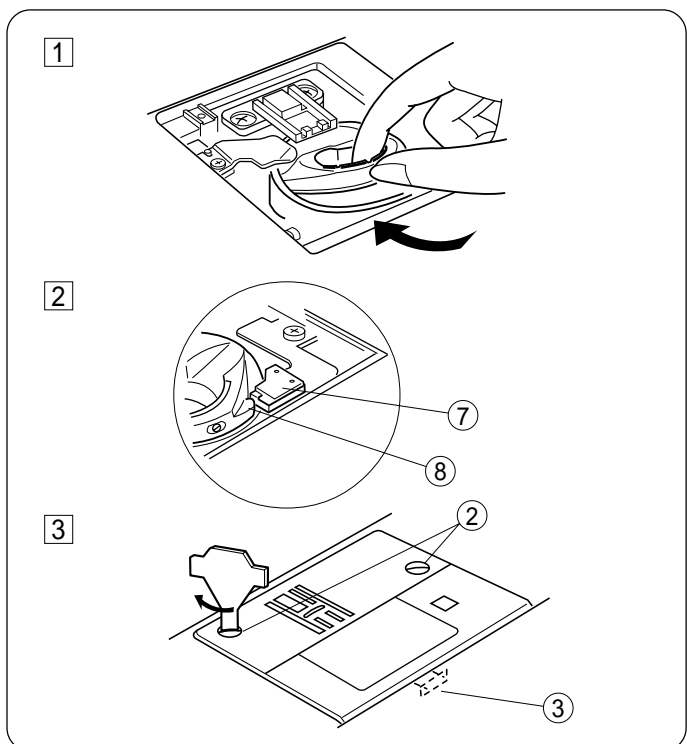

Replacing bobbin holder and needle plate





- 1 Insert the bobbin holder.
- 2 Make sure to fit the knob next to the stopper in the hook race.
 - ⑦ Stopper
 - ⑧ Knob
- 3 Insert the bobbin and attach the needle plate.
Tighten the setscrews firmly.

NOTE: After cleaning the machine, attach the needle and presser foot.

PROBLEMS AND WARNING SIGNALS

When beep sounds and the LED display shows warning signal, follow the guidance below to deal with.

Visual signal

LED	Cause and Action
	The foot control has been disconnected while sewing. Turn OFF the power and connect the foot control.
	A button is pressed when the machine halts due to the overload. Wait for at least 15 seconds to recover. If thread jamming causes overload, remove the tangled threads.
	Pattern selection key is pressed after buttonhole is finished but the foot is not raised. Raise the foot. Do not use the automatic buttonhole foot to sew any other pattern than buttonhole or darning.
	The machine is out of order. Contact the service center or the store from whom the machine was purchased.

Audible Signal

Beep	Beep sounds when:
pip	Normal operation
pip-pip-pip	Invalid operation
pip-pip-peep	Buttonhole is finished.
peep	The machine is out of order.

TROUBLESHOOTING

Condition	Cause	Reference
The needle thread breaks.	<p>The needle thread is not threaded properly.</p> <p>The needle thread tension is too tight.</p> <p>The needle is bent or blunt.</p> <p>The needle is incorrectly inserted.</p> <p>The needle thread and the bobbin thread are not set under the presser foot when start sewing.</p> <p>The threads were not drawn to the rear after sewing.</p> <p>The thread is too heavy or too fine for the needle.</p>	<p>Page 13</p> <p>Page 9</p> <p>Page 10</p> <p>Page 10</p> <p>Page 17</p> <p>Page 17</p> <p>Page 10</p>
The bobbin thread breaks.	<p>The bobbin thread is not threaded properly in the bobbin holder.</p> <p>Lint has collected in the bobbin holder.</p> <p>The bobbin is damaged and doesn't turn smoothly.</p>	<p>Page 12</p> <p>Page 47</p> <p>Change the bobbin</p>
The needle breaks.	<p>The needle is incorrectly inserted.</p> <p>The needle clamp screw is loose.</p> <p>The threads were not drawn to the rear after sewing.</p> <p>The needle is too fine for the fabric being used.</p>	<p>Page 10</p> <p>Page 10</p> <p>Page 17</p> <p>Page 10</p>
Skipped stitches	<p>The needle is incorrectly inserted, bent or blunt.</p> <p>The needle and/or threads are not suitable for the work being sewn.</p> <p>The blue tipped needle is not being used for sewing stretch, very fine fabrics and synthetics.</p> <p>The needle thread is not threaded properly.</p> <p>The poor quality needle is used.</p>	<p>Page 10</p> <p>Page 10</p> <p>Page 10</p> <p>Page 13</p> <p>Change the needle</p>
Seam puckering	<p>The needle thread tension is too tight.</p> <p>The needle thread is not threaded properly.</p> <p>The needle is too heavy for the fabric being sewn.</p> <p>The stitch length is too long for the fabric.</p>	<p>Page 9</p> <p>Pages 13</p> <p>Page 10</p> <p>Make stitch shorter.</p> <p>Use a stabilizer.</p>
The cloth is not feeding smoothly.	<p>The feed dog is packed with lint.</p> <p>The stitches are too fine.</p> <p>The feed dog is not raised after "drop feed" sewing.</p>	<p>Page 47</p> <p>Make stitch longer.</p> <p>Page 7</p>
Loops on the seams	<p>The needle thread tension is too loose.</p> <p>The needle is too thick or too fine for the fabric.</p>	<p>Page 9</p> <p>Page 10</p>
The machine doesn't work.	<p>The machine is not plugged in.</p> <p>Thread has been caught in the hook race.</p> <p>The bobbin winder spindle is not returned to the left after bobbin winding. (Bobbin winding condition)</p>	<p>Page 5</p> <p>Page 47</p> <p>Page 11</p>
Buttonhole sewing is not sewn properly.	<p>The stitch density is not suitable for the fabric being sewn.</p> <p>The suitable interface material has not been used for the stretch or synthetic fabric.</p>	<p>Page 29</p> <p>Page 26</p>
The machine is noisy.	<p>Thread has been caught in the hook race.</p> <p>Lint has built up in the hook race or bobbin holder.</p>	<p>Page 47</p> <p>Page 47</p>

It is normal that a faint humming sound is coming out from the internal motors.

The pattern selection key area may get warm when the machine has been used for hours.

